

## 外部委託業者の募集

References: IO/26/OT/10033393/JPK

### "Procurement of the Heating Neutral Beam 1 (HNB1) and Heating Neutral Beam 2 (HNB2) Vacuum Vessel Pressure Suppression System (VVPSS) Components (B)"

(中性粒子加熱ビーム1と2の真空容器圧力抑制システム (VVPSS) 機器の調達(B))

IO 締め切り 2026年3月31日(火)

#### ○はじめに

本事前情報通知 (PIN) は、作業契約の入札授与および実行につながる公開入札調達プロセスの最初のステップです。

#### ○背景

ITER は平和利用の核融合発電の科学的小および技術的な実現可能性の実証を目的とした、国際共同研究開発プロジェクトです。ITER 機構の7つのメンバーは、;欧州連合 (EURATOM が代表)、日本、中華人民共和国、インド、大韓民国、ロシア連邦、および米国です。

ITER の敷地はフランス南東部のブーシュデュロヌ地区にあり、ITER 本社 (HQ) もあるフランス CEA サン・ポール・レ・デュランス に近いところに位置しています。詳細については、ITER のウェブサイト <http://www.iter.org> を参照して下さい。

#### ○作業範囲

本入札手続きは、「加熱用中性粒子ビーム1 (HNB1)」および「加熱用中性粒子ビーム2 (HNB2)」の真空容器圧力抑制システム (VVPSS) コンポーネントの調達に関連するサービスおよび供給契約の締結を目的としています。

契約の範囲は全9フェーズに分かれており、フェーズ8のみがオプションとして残されており、それ以外のフェーズ0から7まではすべて確定した範囲 (固定スコープ) と見なされます。

本契約の範囲と目的は以下の9つの個別フェーズです。:

- フェーズ0 : プロジェクト管理および品質管理
- フェーズ1 : エンジニアリング
- フェーズ2 : 認証および工場準備
- フェーズ3 : 資材調達
- フェーズ4 : 製造および製造中の試験
- フェーズ5 : 工場受入試験 (FAT)
- フェーズ6 : 梱包、輸送および納品
- フェーズ7 : 現地受入試験 (SAT)
- フェーズ8 (オプション) : ドリフトダクト (DD) とVVPSSボックスの溶接

HNB1およびHNB2のVVPSSコンポーネントは、それぞれインコタームズDAP (仕向地持込渡し) に基づきITERサイトへ納品される予定です。

システム分類および適用されるコード・規格については、附属書IIの5.3.4節をご参照ください。

そこには、原子力安全に関する安全重要クラス1（SIC-1またはSIC-2）、耐震クラス、遠隔操作（RH）クラス、真空クラス、トリチウムクラス、設計コード、製造コードなどが含まれています。

本契約における品質クラスはQC1またはQC2です。

作業はオフサイトおよび／またはオンサイトで実施されます。

## ○調達プロセスと目的

目的は、競争入札プロセスを通じて供給契約を落札することです。

この入札のために選択された調達手続きは公開入札手続きと呼ばれます。

オープン入札手順は、次の4つの主要なステップで構成されています。

### ➤ ステップ1-事前情報通知（PIN）

事前情報通知は公開入札プロセスの第一段階です。IOは、関心のある候補企業に対し、以下の概略日程に示された期日までに担当調達担当官に添付の関心表明フォームで以下の情報を提出し、競争プロセスへの関心を示すよう正式に要請します。

#### 特に注意:

関心のある候補企業は、IO Aribaの電子調達ツール「IPROC」に登録してください（まだ登録していない場合）。手順については、

<https://www.iter.org/fr/proc/overview>

を参照してください。

Ariba (IPROC)に登録する際には、お取引先様に最低1名の担当者の登録をお願いします。この連絡担当者は、提案依頼書の発行通知を受け取り、必要と思われる場合は入札書類を同僚に転送することができます。

### ➤ ステップ2-入札への招待

PINの発行から14作業日以内に、関心を示した入札者に対して入札への招待（IIT）が送付されます。この段階では、PINを確認した関心のある入札者が入札書類を入手し、入札指示に従って提案書を準備・提出することができます。

このツールに登録されている企業のみが入札に招待されます。

### ➤ ステップ3-入札評価プロセス

入札者の提案は、ITER機構の公正で専門的な技術評価委員会によって評価されます。入札者は、技術範囲に従い、入札への招待（IIT）に記載された特定の評価基準に基づいて作業を実施できるこ

とを示す技術的な適合性の詳細を提供する必要があります。

➤ ステップ4-落札

認定は、入札への招待（IIT）に記載されている、コストに見合った最適な価格または技術的に準拠した最低価格に基づいて行われます。

### ○概略日程

概略日程は以下の通りです：

マイルストーン	暫定日程
事前指示書（PIN）の発行	2026年3月19日
関心表明フォームの提出	2026年3月31日
iPROCでの提案依頼書の発行	2026年4月2日
明確化のための質問（もしあれば）と回答締め切り	2026年4月24日
入札提出	2026年4月30日
入札評価及び契約授与	2026年5月
契約調印	2026年5/6月

### ○契約期間と実行

ITER機構は2026年の5月末旬に契約を授与します。予想される契約期間は、3.6年（180週）とします。

### ○経験

入札者は、付属書 I 詳述される作業範囲に従って、技術的、産業的な経験を実証する必要があります。

ITER での使用言語は英語で、流ちょうなプロレベルが求められます（口頭および文書）。

### ○候補

参加は、個人またはグループ/コンソーシアムに参加するすべての法人に開放されます。法人とは、法的権利及び義務を有し、ITER 加盟国内に設立された個人、企業又は機構をいいます。ITER 加盟国は欧州連合(EURATOM メンバー)、日本、中華人民共和国、インド共和国、大韓民国、ロシア連邦、アメリカ合衆国です。

法人は、単独で、またはコンソーシアムパートナーとして、同じ契約の複数の申請または入札に参加することはできません。共同事業体は、恒久的な、法的に確立されたグループ又は特定の入札手続のために非公式に構成されたグループとすることができます。

コンソーシアムのすべての構成員(すなわち、リーダーと他のすべてのメンバー)は、ITER 機構に対して連帯して責任を負います。

コンソーシアムとして許可されるために、その点で含まれる法人はコンソーシアムの各メンバーをまとめる権限をもつリーダーをもたなければなりません。このリーダーはコンソーシアムの各目メンバーのために責任を負わなければなりません。

指名されたコンソーシアムのリーダーは、入札段階で、コンソーシアムのメンバーの構成を説明する予定です。その後、候補者の構成は、いかなる変更も ITER 機構に通知することなく変更してはなりません。かかる認可の証拠は、すべてのコンソーシアムメンバーの法的に授権された署名者が署名した委任状の形式で、しかるべき時期に IO に提出しなければなりません。

どのコンソーシアムメンバーも IPROC に登録する必要があります。

【※ 詳しくは添付の英語版技術仕様書「**Procurement of the Heating Neutral Beam 1 (HNB1) and Heating Neutral Beam 2 (HNB2) Vacuum Vessel Pressure Suppression System (VVPSS) Components (B)**」をご参照ください。】

ITER 公式ウェブ <http://www.iter.org/org/team/adm/proc/overview> からもアクセスが可能です。

「核融合エネルギー研究開発部門」の HP : <http://www.fusion.qst.go.jp/ITER/index.html>  
では ITER 機構からの各募集 (IO 職員募集、IO 外部委託、IO エキスパート募集) を逐次更新しています。ぜひご確認ください。

## ITER国際核融合エネルギー機構からの外部委託 に関心ある企業及び研究機関の募集について

### <ITER 機構から参加極へのレター>

以下に、外部委託の概要と要求事項が示されています。参加極には、提案された業務に要求される能力を有し、入札すべきと考える企業及び研究機関の連絡先の情報を ITER 機構へ伝えることが求められています。このため、本研究・業務に関心を持たれる企業及び研究機関におかれましては、応募書類の提出要領にしたがって連絡先情報をご提出下さい。

## **PRIOR INDICATIVE NOTICE (PIN)**

### OPEN TENDER SUMMARY

IO/26/OT/10033393/JPK

*For*

### ***Procurement of the Heating Neutral Beam 1 (HNB1) and Heating Neutral Beam 2 (HNB2) Vacuum Vessel Pressure Suppression System (VVPSS) Components (B).***

#### **Annexes**

Annex I– Expression of Interest Form

Annex II – Technical Specifications

#### **Abstract**

The purpose of this summary is to provide prior notification of the IO's intention to launch a competitive Open Tender process in the coming weeks. This summary provides some basic information about the ITER Organisation, the technical scope for this tender, and details of the tender process for the procurement of the supplies and services related to the Project management and Quality, Engineering, Qualifications and factory preparation, Factory Acceptance Test (FAT), Packing, Transport and Delivery to the IO site, Site Acceptance

Test (SAT), Transfer of Ownership. Furthermore, the scope of Welding of the Drift Duct (DD) to the VVPSS Box remains as an option.

## 1 Introduction

This Prior Indicative Notice (PIN) is the first step of an Open Tender (OT) Procurement Process leading to the award and execution of a Contract.

The purpose of this document is to provide a basic summary of the technical content in terms of the scope of work and the tendering process.

## 2 Background

The ITER project is an international research and development project jointly funded by its seven Members being, the European Union (represented by EURATOM), Japan, the People's Republic of China, India, the Republic of Korea, the Russian Federation and the USA. ITER is being constructed in Europe at St. Paul–Lez-Durance in southern France, which is also the location of the headquarters (HQ) of the ITER Organization (IO).

For a complete description of the ITER Project, covering both organizational and technical aspects of the Project, visit [www.iter.org](http://www.iter.org).

## 3 Scope of Work

The present tender process aims to establish a Service and Supply Contract related to the Procurement of the Heating Neutral Beam 1 (HNB1) and Heating Neutral Beam 1 (HNB2) Vacuum Vessel Pressure Suppression System (VVPSS) Components. Only Phase 8 is left as an option; the rest (from 0 to 7) are all considered firm fixed scope. The scope and purpose of this contract has 9 distinct Phases:

- Phase 0: Project management and Quality
- Phase 1: Engineering
- Phase 2: Qualifications and factory preparation
- Phase 3: Material Procurement
- Phase 4: Manufacturing and Tests during manufacturing
- Phase 5: Factory Acceptance Test (FAT)
- Phase 6: Packing, Transport and Delivery
- Phase 7: Site Acceptance Test (SAT)
- Phase 8 (**option**): Welding of the Drift Duct (DD) to the VVPSS Box

The delivery of the Heating Neutral Beam 1 (HNB1) and Heating Neutral Beam 1 (HNB2) Vacuum Vessel Pressure Suppression System (VVPSS) Components. Those shall be shipped to the ITER site, respectively, based on the Incoterms DAP ITER site.

Please find the System Classification and applicable Codes & Standards in section 5.3.4 of Annex II, which includes Safety Important Class 1 (SIC-1 or SIC-2) for nuclear class safety and Seismic class, Remote Handling (RH) Class, Vacuum classification, a Tritium Class, Design Codes, and Manufacturing Codes.

The Quality class under this contract is QC1 or QC2.

The work shall be performed off-site and/or on-site.

## 4 Procurement Process & Objective

The objective is to award a Supply Contract through a competitive bidding process.

The Procurement Procedure selected for this tender is called the **Open Tender** procedure.

The Open Tender procedure is comprised of the following four main steps:

### ➤ Step 1- Prior Information Notice (PIN)

The Prior Information Notice is the first stage of the Open Tender process. The IO formally invites interested Suppliers to indicate their interest in the competitive process by returning to the Procurement officer in charge the attached “Expression of Interest and PIN Acknowledgement” by the date indicated under the procurement timetable.

#### **Special attention:**

**Interested tenderers are kindly requested to register in the IO Ariba e-procurement tool called “IPROC”. You can find all links to proceed along with instruction going to: <https://www.iter.org/fr/proc/overview>.**

**When registering in Ariba (IPROC), suppliers are kindly requested to nominate at least one contact person. This contact person will be receiving the notification of publication of the Request for Proposal and will then be able to forward the tender documents to colleagues if deemed necessary.**

### ➤ Step 2 - Invitation to Tender

After at least 15 working days of the publication of the PIN, normally the Request for Proposals (RFP) will be published on our digital tool “Iproc”. This stage allows interested bidders who have indicated their interest to the Procurement Officer in charge AND who have registered in IPROC to receive the notification that the RFP is published. They will then prepare and submit their proposals in accordance with the tender instructions detailed in the RFP.

**Only companies registered in this tool will be invited to the tender.**

### ➤ Step 3 – Tender Evaluation Process

Tenderers proposals will be evaluated by an impartial evaluation committee of the IO. Tenderers must provide details demonstrating their technical compliance to perform the work in line with the technical scope and in accordance with the particular criteria listed in the RFP.

### ➤ Step 4 – Contract Award

A Service contract will be awarded on the basis of the Best Value For Money methodology according to the evaluation criteria and methodology described in the RFP.

## Procurement Timetable

The tentative timetable is as follows:

Milestone	Date
Publication of the Prior Indicative Notice (PIN)	19 March 2026
Submission of expression of interest form	31 March 2026
Invitation to Tender (ITT) advertisement	2 April 2026
Clarification Questions (if any) and Answers	24 April 2026
Tender Submission	30 April 2026
Tender Evaluation & Contract Award	May 2026
Contract Signature	May/June 2026

## 5 Quality Assurance Requirements

Prior to the commencement of any work under this Contract, a “Quality Plan” shall be produced by the Supplier and submitted to the IO for approval, describing how they will implement the ITER Procurement Quality Requirements.

## 6 Contract Duration and Execution

The ITER Organisation shall award the Service Contract around the end of May 2026. The estimated contract duration shall be 3.6 years (180 weeks).

## 7 Cost Range

This scope of work is identified at Cost Range C, which is above 4,000,000 - 12,000,000 EUR.

## 8 Experience

The tenderer shall demonstrate their technical and industrial experience related to the scope of work as detailed in Annex I.

The working language of ITER is English, and a fluent professional level is required (spoken and written).

## 9 Candidature

Participation is open to all legal entities participating either individually or in a grouping/consortium. A legal entity is an individual, company, or organization that has legal rights and obligations and is established within an ITER Member State, being, the European Union (represented by EURATOM), Japan, the People’s Republic of China, India, the Republic of Korea, the Russian Federation and the USA.

Legal entities cannot participate individually or as a consortium partner in more than one application or tender of the same contract. A consortium may be a permanent, legally established grouping, or a grouping which has been constituted informally for a specific tender procedure. All members of a consortium (i.e. the leader and all other members) are jointly and severally liable to the ITER Organization.

In order for a consortium to be acceptable, the individual legal entities included therein shall have nominated a consortium leader with authority to bind each member of the consortium, and this leader shall be authorised to incur liabilities and receive instructions for and on behalf of each member of the consortium.

It is expected that the designated consortium leader will explain the composition of the consortium members in its offer. Following this, the Candidate’s composition must not be modified without notifying the ITER

Organization of any change. Evidence of any such authorisation to represent and bind each consortium member shall be submitted to the IO in due course in the form of a power of attorney signed by legally authorised signatories of all the consortium members.

Any consortium member shall be registered in IPROC.

## **10 Sub-contracting Rules**

All sub-contractors who will be taken on by the Contractor shall be declared together with the tender submission. Each sub-contractor will be required to complete and sign forms including technical and administrative information which shall be submitted to the IO by the tenderer as part of its tender.

The IO reserves the right to approve any sub-contractor which was not notified in the tender and request a copy of the sub-contracting agreement between the tenderer and its sub-contractor(s).

Sub-contracting is allowed but it is limited to one level and its cumulated volume is limited to 40% of the total Contract value.



IDM UID <b>EYJES3</b>
VERSION CREATED ON / VERSION / STATUS <b>17 Mar 2026 / 1.2 / Approved</b>
EXTERNAL REFERENCE / VERSION

**Technical Specifications (In-Cash Procurement)**

**TS\_VVPSSB\_VVPSSBT\_Procurement**

TS\_VVPSSB\_VVPSSBT\_Procurement

SUPPLY

Table of Contents

**1 PREAMBLE.....6**

**2 PURPOSE.....6**

**3 ACRONYMS & DEFINITIONS .....6**

    3.1 Acronyms .....6

    3.2 Definitions.....8

**4 APPLICABLE DOCUMENTS & CODES AND STANDARDS.....8**

    4.1 Applicable Documents .....8

    4.2 Applicable Codes & Standards .....12

        4.2.1 Code for the VVPSS Box items .....12

        4.2.2 Temporary tools and equipment .....12

**5 SCOPE OF WORK.....13**

    5.1 Scope of Supply .....13

    5.2 Hardware.....13

    5.3 Description of the Procurement .....14

        5.3.1 Overview of the NB system .....14

        5.3.2 Functions of the VVPSS Boxes .....16

        5.3.3 Description of the VVPSS Box Items .....17

            5.3.3.1 HNB VVPSS Boxes description .....18

            5.3.3.2 VVPSS box Trolley Support .....19

            5.3.3.3 VVPSS box Blank Flange .....19

            5.3.3.4 VVPSS box Anchor System.....20

            5.3.3.5 Baking and I&C system of the VVPSS Box description .....20

        5.3.4 Classification of the VVPSS Box Items .....21

        5.3.5 General Technical Interfaces.....23

    5.4 WBS .....23

        5.4.1 WP\_PM0 – Project management, Quality, and Nuclear Safety.....24

        5.4.2 WP\_E1 – Engineering.....24

        5.4.3 WP\_Q2 – Qualifications and factory preparation.....24

        5.4.4 WP\_P3 – Procurement .....25

        5.4.5 WP\_M4 – Manufacturing .....25

        5.4.6 WP\_T5 – Factory Acceptance Testing .....25

        5.4.7 WP\_D6 – Packing, Transport and Delivery.....25

        5.4.8 WP\_S7 - Site Acceptance Tests and Final acceptance. ....26

    5.5 Option: Welding the VVPSS box to the Drift Duct.....26

**SUPPLY**

5.5.1	Description of the interface .....	26
5.5.2	Overview .....	28
5.5.3	Documentation .....	29
5.5.4	– Study .....	30
5.5.5	Manufacturing and testing operations .....	31
5.5.6	Acceptance of OPTION .....	32
5.6	CAD Models .....	32
5.7	Scope of Contract.....	32
5.7.1	Related activities .....	32
5.7.2	Manufacture of the Component .....	33
5.7.3	Design change Post FDR. ....	34
5.7.4	Documentation .....	34
5.7.4.1	FDR .....	34
5.7.4.2	Manufacturing Readiness Review (MRR) .....	34
5.7.5	Share of Responsibilities.....	38
5.7.6	Procurement follow-up .....	39
5.7.6.1	Notification Points, Authorizations-to-Proceed Points, Hold Points, Witness Points .....	39
5.7.6.2	Data Management.....	43
5.7.6.3	IO Reviews.....	43
<b>6</b>	<b>TECHNICAL REQUIREMENTS .....</b>	<b>44</b>
6.1	Nuclear Safety Information & requirements.....	44
6.1.1	Nuclear Safety Information.....	44
6.1.2	Nuclear Safety requirements .....	45
6.2	General requirements .....	45
6.3	Functional requirements .....	46
6.4	Material .....	46
6.5	Manufacturing requirements .....	52
6.6	Requirements for the manufacturing of vacuum components .....	53
6.7	Welding .....	54
6.7.1	Welder and Operator Qualification.....	54
6.7.2	Welding Procedure Qualification Record .....	55
6.7.3	Welding Procedure requirements .....	55
6.7.4	Welding Procedure Qualification (WPQ) .....	56
6.7.5	Acceptance of Filler material .....	56
6.7.6	Qualification of Workshops of VVPSS box Items .....	57
6.7.7	Weld production.....	57
6.7.7.1	Storage and use of the welding materials .....	57
6.7.7.2	Preparation and Examination of Edges and Surfaces for Welding .....	57
6.7.7.3	Execution of production welds.....	58
6.7.7.4	Repair by welding .....	59
6.7.7.5	Production Weld Test Coupons and Production Proof Sampling .....	59

**SUPPLY**

6.7.7.6	Before welding .....	59
6.7.7.7	Welding documentation .....	59
6.7.7.8	Weld related heat treatments .....	60
6.8	<b>Machining .....</b>	<b>60</b>
6.8.1.1	Metallic seals groove machining requirements .....	60
6.9	<b>Coating .....</b>	<b>62</b>
6.10	<b>Pickling .....</b>	<b>62</b>
6.11	<b>Painting .....</b>	<b>63</b>
6.12	<b>Manufacturability and Standardization requirements .....</b>	<b>63</b>
6.13	<b>Installation and Integration requirements .....</b>	<b>63</b>
6.14	<b>Instrumentation and Control requirements .....</b>	<b>63</b>
6.14.1	General requirements .....	63
6.14.2	<b>Common Requirement Applicable to Thermocouple Cable Assemblies and the insulated Heating cable assemblies .....</b>	<b>65</b>
6.14.2.1	Material .....	65
6.14.2.2	Generalities .....	66
6.14.2.3	Condition of use .....	67
6.14.2.4	Manufacturing requirements .....	67
6.14.2.5	Requirements related to Brazing of the MICs .....	67
6.14.2.6	Requirements related to welding .....	68
6.14.2.7	Marking and traceability .....	68
6.14.2.8	Documentation to be provided before manufacturing .....	69
6.14.2.9	Documentation to be provided after manufacturing .....	70
6.14.2.10	Manufacturing controls .....	70
6.14.3	Specific Thermocouple Sensor cable assembly requirements .....	72
6.14.4	Specific Heater cable assembly requirements .....	73
6.15	<b>Operation and Maintenance Requirements .....</b>	<b>74</b>
6.15.1	Special Tools .....	74
6.15.2	Spare Parts .....	74
6.15.3	Training of Operators .....	75
6.16	<b>Power supply and control command system for the VVPSS Box baking 75</b>	<b>75</b>
<b>7</b>	<b>INSPECTION AND TESTING .....</b>	<b>77</b>
7.1	<b>Examination and Tests .....</b>	<b>77</b>
7.1.1	<b>Examination during manufacturing .....</b>	<b>77</b>
7.1.1.1	General requirements .....	77
7.1.1.2	Surface examination .....	78
7.1.1.3	Volumetric examination .....	79
7.1.1.4	Alternative NDE .....	79
7.1.2	<b>Tests during manufacturing .....</b>	<b>80</b>
7.1.3	<b>Factory acceptance test .....</b>	<b>81</b>
7.1.3.1	Dimensional check .....	82
7.1.3.2	Visual examination .....	82
7.1.3.3	Metallic seals and grooves .....	82
7.1.3.4	Electrical test of Thermocouples and Heating Elements Cable Assemblies .....	83
7.1.3.5	Test of the Baking function .....	83
7.1.3.6	Vacuum Leak test (cold) .....	84
7.1.3.7	Vacuum Leak test (Hot) .....	87

**SUPPLY**

7.1.3.8	Outgassing rate acceptance test.....	91
7.1.3.9	Functional Test of the VVPSSB Trolley.....	92
7.1.4	Factory acceptance test Final Report .....	93
7.2	Metrology and Tolerances .....	93
7.2.1	Dimensional control .....	94
7.2.2	Roughness measurement.....	94
7.2.3	Metrology and tolerances Final Report.....	94
7.3	Acceptance Criteria.....	95
7.4	Final IO site Acceptance .....	95
<b>8</b>	<b>REQUIREMENTS FOR LABELLING, CLEANING, PACKAGING, HANDLING, SHIPMENT AND STORAGE .....</b>	<b>96</b>
8.1	Scope of Application.....	96
8.2	Labelling .....	96
8.2.1	Identification and marking procedure .....	96
8.2.2	General marking requirements.....	97
8.3	Traceability requirements .....	98
8.4	Cleaning .....	98
8.4.1	Final cleaning requirements .....	101
8.4.2	Cleanliness of work areas .....	102
8.4.3	Cleanliness control of the component .....	103
8.4.4	Requirements related to the contamination.....	104
8.4.5	Cleaning Final Report .....	104
8.5	Packaging and Handling .....	104
8.5.1	Packing.....	104
8.5.2	Delivery Report.....	106
8.5.3	Handling.....	107
8.6	Shipping requirements .....	107
8.6.1	Generalities .....	107
8.6.2	Transportation and delivery to ITER site.....	107
8.6.3	Delivery Acceptance after transport to IO site.....	108
<b>9</b>	<b>COMMISSIONING .....</b>	<b>109</b>
<b>10</b>	<b>LOCATION FOR SCOPE OF WORK EXECUTION .....</b>	<b>109</b>
<b>11</b>	<b>IO FREE ISSUE ITEMS.....</b>	<b>109</b>
11.1	Documentation provided with the free issued items .....	109
11.2	Unpacking .....	109
11.3	Packing.....	110
11.4	Incoming inspection .....	110
11.4.1	Documentation .....	110

**SUPPLY**

11.4.1.1	Incoming inspection procedures.....	110
11.4.1.2	Incoming inspection reports .....	110
11.4.2	Incoming inspection of the components free issued .....	111
11.5	Responsibilities .....	111
<b>12</b>	<b>DELIVERABLES AND SCHEDULE MILESTONES .....</b>	<b>111</b>
12.1	Schedule for delivery .....	111
12.2	List of deliverable documentation.....	112
<b>13</b>	<b>QUALITY ASSURANCE REQUIREMENTS.....</b>	<b>113</b>
<b>14</b>	<b>SPECIAL MANAGEMENT REQUIREMENTS .....</b>	<b>114</b>
14.1	Work Monitoring .....	115
14.2	Meeting Schedule.....	117
14.3	CAD design requirements .....	118
<b>15</b>	<b>APPENDICES .....</b>	<b>118</b>
	<b>APPENDIX I – LIST OF DELIVERABLE SUPPLIES .....</b>	<b>119</b>
	<b>APPENDIX II – LIST OF MILESTONES.....</b>	<b>122</b>
	Table 1 – Component Breakdown Structure.....	13
	Table 2 Classifications (I) of the VVPSS Box.....	21
	Table 3 Classifications (II) of the VVPSS Box .....	21
	Table 4 Classifications (I) of the VVPSS Boxes (HNB1 & HNB2).....	22
	Table 5 Classifications (II) of the DD.....	22
	Table 6 Top level WBS of the project .....	23
	Table 7 <i>List of documents to be provided at the MRR</i> .....	35
	Table 8 List of documentation to be provided during Technical review Milestone .....	36
	Table 9 List of documentation to be provided during Technical review Milestone .....	38
	Table 10 Preliminary List of control points and associated documentation.....	41
	Table 11 Definition of Baking System on VVPSS Box .....	64
	Table 12 MICs material [75].....	65
	Table 13 VVPSS Box Liner Heating Elements .....	76
	Table 14: Labelling of VVPSS .....	96
	Table 15: Free Issue items .....	109
	Table 16: Schedule for Delivery .....	112
	Table 17 Main reviews.....	117
	Table 18 – List of deliverables.....	119
	Table 19 – List of Milestones .....	122

**SUPPLY**

Figure 1: Isometric view of the NB-Cell .....15  
Figure 2: Top view of VVPSS line in the NB Cell configuration PFP01 .....15  
Figure 3: VVPSS Boxes HNB1 and HNB2 in configuration SRO .....16  
Figure 4: HNB1 VVPSS Box .....17  
Figure 5: NB FEC connected to the NB Port.....17  
Figure 6: General view of the DD with the VVPSS Box .....18  
Figure 7: General views of HNB1 VVPSS Box (Interface DN500) .....18  
Figure 8: General views of HNB2 VVPSS Box (interface DN300).....19  
Figure 9: General view of The VVPSS box Trolley support.....19  
Figure 10: General view of The VVPSS box Blank Flange .....20  
Figure 11: General view of The VVPSS box Anchor System.....21  
Figure 12: General views of Baking and I&C system of the VVPSS box .....21  
Figure 13 : Batch VVPSS Box Welded to the Drift Duct.....27  
Figure 14 : Batch VVPSS Box Welded to the Drift Duct.....27  
Figure 15: Interface between the DD & VVPSS Box.....31  
Figure 16: CATIA Model .....33  
Figure 14: Machining method for Metallic seal groove .....61  
Figure 15: Zoning of the Electrical Heaters.....65  
Figure 19: Zoning of the VVPSS Box and VVPSSB Blank Flange.....76  
Figure 20: General views of Closure and Blank Flanges .....87

## SUPPLY

### 1 Preamble

This Technical Specification is to be read in combination with the General Management Specification for Service and Supply (GM3S) – Ref [2] that constitutes a full part of the technical requirements.

In case of conflict, the content of the Technical Specification supersedes the content of Ref [2].

### 2 Purpose

The document is the key documentation that defines the technical scope of the procurement of the HNB1 and HNB2 VVPSS Components.

### 3 Acronyms & Definitions

#### 3.1 Acronyms

The following acronyms are the main one relevant to this document.

Abbreviation	Description
DD	Drift-Duct
BLC	Beam Line Component
BS	Beam Source
CP	Cryopump
CRO	Contract Responsible Officer
CW	Cooling Water
DA	Domestic Agency
DCP	Dimensional Control Plan
DNB	Diagnostic Neutral Beam
DWB	Double Walls Bellows
EMR	End of Manufacturing Report
ES	Exit Scraper
EBW	Electron Beam Welding
FAT	Factory Acceptance Test
FDR	Final Design Review
FEC	Front End Components
FR	Functional Reference
FS	Fast Shutter
GM3S	General Management Specification for Service and Supply
HNB	Heating Neutral Beam
H&CD	Heating and Current Drive
HV	High Voltage
HVB	High Voltage Bushing

**SUPPLY**

IO	ITER Organization
ICD	Interface Control Document
IS	Interface Sheet
ITER	International Thermonuclear Experimental Reactor
L1	Level 1 of the Tokamak Building
LDP	Liquid Dye Penetrant
LS	Load Specification
PT	dye or liquid Penetrant Test
MIP	Manufacturing and Inspection Plan
NED	Neutralizer and Electron Dump
NDE	Non Destructive Examination
NDT	Non Destructive Test
NB	Neutral Beam
PA	Procurement Arrangement
PIA	Protection Important Activities
PMS	Passive Magnetic Shield
PNI	Part Number of ITER
PPS	Production Proof Sampling
PR	Project Requirement
PRO	Procurement Responsible Officer
PQR	Procedure Qualification Record: a record of the parameters used during the WPQ defining the requirements of applicable codes and standards
PS&CC-S	Power Supply and Command Control System
RH	Remote Handling
RID	Residual Ion Dump
RPM	Requirements Propagation Matrix
RT	Radiography Test
SN	Serial Number
SVS	Service Vacuum System
TC	Thermocouple
TS	Technical Specification
VHB	Vacuum Handbook
VT	Visual Test
VV	Vacuum Vessel
VVPSS Box	Vacuum Vessel Pressure Suppression System Box
VVCD	Vacuum Vessels Connecting Duct
WDP	Welding Data Package. It groups various information related to the welding procedures, qualifications and test coupons for a component.
WPDS	Welding Procedure Data Sheets. It defines the area of validity of the qualification it is derived.

**SUPPLY**

WPQ	Welding Procedure Qualification: intended to provide proof of weldability of a metal with a particular process, using the parameters stated in the WPS
WPQR	Procedure Qualification Report: a record of the parameters used during the WPQ defining the requirements of applicable codes and standards
WPS	Welding Procedure Specification: defines the requirements of a WPS, a document providing the welder or operator specific instructions on how to complete a welded joint
WQTR	Welder Qualification Test Record is intended to prove welder/welding operator's ability to deposit sound welded metal when using a qualified WPS

**3.2 Definitions**

**Contractor:** shall mean an economic operator who have signed the Contract in which this document is referenced.

**VVPSS BOX ITEMS :** this batch of components includes:

- The VVPSS Box HNB1 [59]
- The VVPSS box HNB2 [59]
- The VVPSSB Trolley support (X2) [61]
- The VVPSS Blanking Flange (X2) [59]
- The VVPSSB Anchor System (X2) [59]

Each technical requirement in this TS is formally identified.

A **Requirement** unambiguously starts with a paragraph containing the string [53\_IO\_NB\_VVPSSBT – R NNN] where "N" is a number between 0 and 9.

**Defined requirements are stamped in Red.**

**Information** unambiguously starts with a paragraph containing the string [53\_IO\_NB\_VVPSSBT – INFO NNN] where "N" is a number between 0 and 9

It provides background information to improve the understanding of the requirements. There is thus no need, for the Contractor to demonstrate compliance of 'Information'.

**4 Applicable Documents & Codes and standards**

**4.1 Applicable Documents**

[53\_IO\_NB\_VVPSSBT- INFO 01] This is the responsibility of the Contractor to identify and request for any documents that would not have been transmitted by IO, including the below list of reference documents.

[53\_IO\_NB\_VVPSSBT- INFO 02] This Technical Specification takes precedence over the referenced documents. In case of conflicting information, this is the responsibility of the Contractor to seek clarification from IO.

**SUPPLY**

[53\_IO\_NB\_VVPSSBT- INFO 03] Upon notification of any revision of the applicable document transmitted officially to the Contractor, the Contractor shall advise within 4 weeks of any impact on the execution of the contract. Without any response after this period, no impact will be considered.

[53\_IO\_NB\_VVPSSBT- INFO 04] **Procurement Applicable Document** are those documents containing provisions that constitute mandatory requirements of the Contract imposed by ITER Organisation.

Procurement Applicable Documents			
Ref	Title	IDM Doc ID	Version
1	Standards RCC-MRX 2022	NA	NA
2	General Management Specification for Service and Supply (GM3S)	82MXQK	1.4
3	<a href="#">ITER_D_X5EYSK - NB FEC Trolley Support Load Specification</a>	X5EYSK	4.1
4	ITER_D_434QCS - Loads specification for VVPSS box	434QCS	13.2
5	ITER Vacuum Handbook - ITER_D_2EZ9UM	2EZ9UM	2.5
6	ITER_D_REYV5V - Chemical composition and impurity requirements for materials	REYV5V	3.0
7	ITER Document Breakdown Structure Overview	43327Q	1.1
8	ITER Tritium Handbook ITER_D_2LAJTW	2LAJTW	1.4
9	ITER Plant Breakdown Structure (PBS)	28WB2P	2.0
10	Vacuum Handbook Attachment 1- Welding ITER_D_2FMM4B	2FMM4B	1.5
11	<a href="#">ITER_D_4EUQFL - MQP L2 Overall Surveillance Plan of the Chain of External Actors for Protection Important Components, Structures and Systems and Protection Important Activities</a>	4EUQFL	8.2
12	Vacuum Handbook Appendix -12 Leak Testing	2EYZ5F	1.4
13	ITER Dimensional Metrology Handbook - ITER_D_46FN9B	46FN9B	2.1
14	<a href="#">ITER_D_SBYJXD - Guideline for Identification of the Protection Important Activities (PIA)</a>	SBYJXD	1.4
15	ITER_D_2EL9Y6 – ITER Vacuum Handbook Appendix 2 Environmental Cleanliness	2EL9Y6	1.4
16	ITER_D_U65RWF - Surveillance plan for PBS 53 – Annex 2: Detailed List of PIAs	U65RWF	1.2
17	<a href="#">ITER_D_8NZYWG - BOM VVPSS Boxes</a>	8NZYWG	2.1
18	<a href="#">ITER_D_CRTCHE - BOM VVPSSB TROLLEY</a>	CRTCHE	3.1
19	<a href="#">ITER_D_22K4QX - ITER Quality Assurance Program (QAP)</a>	22K4QX	8.5
20	ITER_D_7XHYN5 – Procurement Specification for supply NiCr19Fe19Nb5Mo3_NB Bolts V1.4	7XHYN5	1.4
21	ITER_D_VYJ7U2 - Procedure for Labelling on Physical Items v1.4	VYJ7U2	1.4

## SUPPLY

22	Assembly drawing interface between Drift-Duct and NB VVPSS-Box reference <a href="#">070129 Version (---)</a> <a href="#">DRIFT_DUCT_VVPSS_BOX_ASSEMBLY_DRW</a> ITER_D_98GFTC	98GFTC	---
23	ITER Procurement Quality requirement	22MFG4	6.3
24	Requirement for Producing a Quality Plan	22MFG4	6.4
25	Requirement for producing an inspection plan	22MFG4	6.4
26	Procedure for Management of Non-conformities	22F53X	9.1
27	Provision for implementation of the Generic safety requirements by the external actors/ interveners.	SBSTBM	2.3
28	Order dated 7th Feb 2012 relating to the general technical regulation applicable to INB.	7M2YKF	1.7
29	Working Instruction for the Qualification of ITER Safety Codes	258LKL	3.1
30	Overall Surveillance Plan of the Chain of External Actors for Protection of Important Components, Structures and Systems, and Protection of Important Activities	4EUQFL	7.4
31	Quality Classification determination	24VQES	6.0
32	<a href="#">ITER_D_2E346G - PA Monthly Report Template</a>	2E346G	1.4
33	Working Instruction for the Delivery Readiness Review (DRR)	X3NEGB	3.0
34	<a href="#">ITER_D_2LZJHB - MQP L3 Procedure for the management of Deviation Request</a>	2LZJHB	9.1

[53\_IO\_NB\_VVPSSBT- INFO 05] Reference documents are documents containing information and/or data for consultation, useful in enhancing understanding of a given subject, and putting the Procurement Applicable Documents in the right and understandable context. Reference Documents are not binding and therefore evidence of propagation or compliance is not expected.

Reference Documents			
Ref	Title	IDM Doc ID	Version
51	[51] SRD-53-01, -02, -03 (NBH&CD) - ITER_D_28B37M v4.4	28B37M	4.4
52	In-vessel Components, SDC-IC - ITER_D_222RHC	222RHC	3.0
52	54 - Interface Sheet 23-53 – ITER_D_323NWG - IS-23-53-003 - HNB VVPSS Box Bellows/VVPSS and NBRHS	323NWG	5.3
53	RPM from PR to SRD-53-01 (ITER_D_PYJXYC v2.0)	PYJXYC	2.0
54	ITER_D_QV7GQF - Inspection Plan (IP) Template v1.3	QV7GQF	1.3

## SUPPLY

55	Vacuum Handbook Appendix 14 – Guide to Passivation and Pickling for the ITER project - ITER_D_2F457S v1.2	2F457S	1.2
56	Code and Standards for ITER Mechanical Components 25EW4K v4.0	25EW4K	4.0
57	ITER Vacuum Handbook Appendix 17 - Guide to Outgassing Rates and their Measurement (2EXDST v2.2)	2EXDST	2.2
58	ITER_D_LAMFG2 - Defined requirements for PBS53 V4.5	LAMFG2	4.5
59	ITER_D_2X4LBS – Description Report of the VVPSS Box ( HNB1-HNB2-HNB3) V2	2X4LBS	2.0
60	ITER_D_6CLGYD - Weld table VVPSS Box post FDR V1.4	6CLGYD	2.0
61	ITER_D_CRTJE7 - Design_Description_Report_VVPSSB_Trolley v1.1	CRTJE7	1.1
62	MRR - ITER_D_44SZYP V5.0 – Working Instruction for Manufacturing Readiness Review	44SZYP	5.0
63	ITER_D_222U38-316L- Composition V3.1	222U38	3.1
64	ITER_D_65UUDC - VVPSS Box-VVPSS - Component failure analysis report V4.0	65UUDC	4.0
65	ITER_D_U6ZDQW V1.1 - Surveillance Plan for PBS 53 - Neutral Beam Heating & Current Drive	U6ZDQW	1.1
66	ITER_D_2Y6KZ5 - 4 - 5 - 6 - Final Design Description of the HNB VVPSS Box - Design evolution & Manufacturing assessment v1.0	2Y6KZ5	1.0
67	ITER_D_3B6JBS - Analysis Report HNB VVPSS Box v2.0	3B6JBS	2.0
68	ITER_D_C3DEDM - Acceptance leak rate for NB enclosure components v1.0	C3DEDM	1.0
69	ITER_D_222RLN - Appendix A, Materials Design Limit Data v3.3	222RLN	3.3
70	Ansys Models of HNB VVPSS Box & HNB Trolley V1.0		
71	Request for Fluid Acceptance (48XLVJ) v2.0	48XLVJ	2.0
72	Fluid and Processing Material Approval Request ITER_D_VH2KDW (folder)	VH2KDW	NA
73	ITER Vacuum Handbook Appendix 4 Accepted Fluids ITER_D_2ELN8N V1.14	2ELN8N	1.14
74	DET- => to be delivered at the KOM		
75	Not used		
76	<a href="#">070129 - DRIFT_DUCT_VVPSS_BOX_ASSEMBLY_DRW</a>	98GFTC	---
77	<a href="#">ITER_D_2ELUQH - Appendix 13 Cleaning and Cleanliness</a>	2ELUQH	1.2

**SUPPLY**

78	ITER Numbering System for Components and Parts (28QDBS)	28QDBS	5.0
79	ITER_D_SLLKUQ - RPT01-01_Welding_Feasibility_Study_PO4100013848	SLLKUQ	1.1

**4.2 Applicable Codes & Standards**

[53\_IO\_NB\_VVPSSBT- INFO 06] The choice of the design and manufacturing codes depends mainly on the Quality Classification as explained in [56].

The applicable codes and standards for the VVPSS Boxes (HNB1 & HNB2) components are defined in the table 1 above.

**4.2.1 Code for the VVPSS Box items**

[53\_IO\_NB\_VVPSSBT- INFO 07] During the Final Design phase, the VVPSS Box Items have been designed according to the RCC-MRX [1] code.

- Design Description of the VVPSS Box ( Final Design) [59]
- VVPSS Box & Trolley Welding table [60]
- Design Description of the VVPSSB Trolley [61]

[53\_IO\_NB\_VVPSSBT- INFO 08] The VVPSS box flanges, bolting and sealing are part of the first confinement barrier.

[53\_IO\_NB\_VVPSSBT-R 001] The VVPSS Box Items shall be manufactured according to the RCC-MRX class N2<sub>RX</sub> [1].

[53\_IO\_NB\_VVPSSBT-R 002] Welding shall be compliant to French Nuclear code RCC-MRX code [1]

[53\_IO\_NB\_VVPSSBT-R 003] Welding procedures shall be qualified according to the requirements of the code (RCC-MRX) as presented in section 6.7 of this TS.

[53\_IO\_NB\_VVPSSBT- INFO 09] The welding documents to be provided by the supplier to the IO are those specified in RS 1200 [1].

[53\_IO\_NB\_VVPSSBT-R 004] The supplier shall generates the Welding Data Package (WDP) specified in RS 1210 [1].

[53\_IO\_NB\_VVPSSBT- INFO 10] Regarding welding procedure qualification the mentioned information is available in the RCC-MR [1] chapters RS 3000.

[53\_IO\_NB\_VVPSSBT-R 005] If the supplier would like to choose a Nuclear Pressure equipment code other than the RCC-MRX, they shall demonstrate the equivalent compliance to RCC-MRX requirements (design & manufacturing) by a reconciliation document to be approved by IO.

**SUPPLY**

*4.2.2 Temporary tools and equipment*

[53\_IO\_NB\_VVPSSBT- INFO 11] Some of the parts to be procured as defined in the Bills of Material [17] & [18], will not be used during the NB operations.

[53\_IO\_NB\_VVPSSBT- INFO 12] These parts are not SIC-1, they do not need to comply with the Chemical composition and impurity requirements for materials [6] & [63], and they don't need to follow the RCC-MRX code [1] class N2<sub>RX</sub>. They are identified in the BOM and will be manufactured according to RCC-MRX [1] class N3<sub>RX</sub> as indicated in the Bills of Material [17] & [18].

[53\_IO\_NB\_VVPSSBT- INFO 13] These parts are the ones corresponding to the following 2D Assembly drawings numbers. These parts will only be needed for the FAT, the transportation and/or the long-term storage.

Commented [MU11]: Wait for BOM

**5 Scope of Work**

[53\_IO\_NB\_VVPSSBT- INFO 14] This section defines the specific scope of work, in addition to the contract execution requirement as defined in Ref [2].

**5.1 Scope of Supply**

[53\_IO\_NB\_VVPSSBT- INFO 15] The scope of this Tender is the procurement and the delivery of the components defined in [17] and [18].

[53\_IO\_NB\_VVPSSBT- INFO 16] In addition, the following components will be designed and delivered by the supplier:

- The Mineral Insulated Cables to be installed on the VVPSS Box and Blank Flange
- The PS&CC-S,
- And generally, any tool, jig, and support necessary for the DD manufacturing and transportation.

[53\_IO\_NB\_VVPSSBT- INFO 17] The component breakdown structure for the scope of supply is indicated in Table 1:

Component	CODE	Drawing number and title	Design maturity
VVPSS BOX HNB1	VB1	HNB1_VVPSS_BOX - 067705	BiP
VVPSS BOX HNB2	VB2	HNB2_VVPSS_BOX - XXXXX	BiP
VVPSSB TROLLEY	VB1	XXXXXXXXXXXXXXXXXXXXXXXXXX	BiP
BLANK FLANGE	BF		BiP
ANCHOR SYSTEM	AS		BiP
Other components	OTH	Closure Plate (067836, 067759)	BiP

Table 1 – Component Breakdown Structure

## SUPPLY

### 5.2 Hardware

[53\_IO\_NB\_VVPSSBT-R 006] The components specified in [17] & [18] shall be produced or supplied by the contractor and shall be delivered to the final place of delivery.

[53\_IO\_NB\_VVPSSBT-R 007] In addition, any tool specifically designed and/or procured by the supplier for the completion of the contract shall be delivered to IO.

[53\_IO\_NB\_VVPSSBT- INFO 18] The equipment needed for the fabrication and factory tests, not listed in the BoM, that is available off the shelf, like for instance pumps and leak detectors needed for the leak tests, are not required to be delivered.

[53\_IO\_NB\_VVPSSBT-R 008] The supplier shall procure and deliver to IO the spare parts defined in [17] & [18].

[53\_IO\_NB\_VVPSSBT-R 009] In addition, the Supplier shall have available :

1. For production: all the necessary fixtures (off the shelf and custom), jigs and frames as well as handling equipment or special tools, as needed and, NDE equipment (including RT equipment) in accordance with the schedule needs, as provided with the tender offer.
2. For factory acceptance tests and other tests: all equipment (off the shelf and custom) needed to perform the tests.
3. For final transport from manufacturing workshop to the final place of delivery: all special lifting equipment and final transport equipment for each NBV.
4. Metrology Hardware as needed to perform Alignment and Metrology activities, and related software.

### 5.3 Description of the Procurement

#### 5.3.1 Overview of the NB system

[53\_IO\_NB\_VVPSSBT- INFO 19] The NB system for ITER consists of two heating and current drive (H&CD) NB injectors and a Diagnostic Neutral Beam (DNB) injector. The layout allows a possible third HNB injector to be installed later. These NB injectors will be connected to equatorial ports #4 - #6 for the H&CD NBs. The DNB (out of the scope of this TS) shares port #4 with the H&CD NB. The injectors will be located outside the cryostat inside a common enclosure, the NB cell, on north side of the Tokamak building in the L1 and the L2 levels. As they are directly coupled to the ITER vacuum vessel, the injectors are extensions of the primary confinement barrier of radioactive materials coming from the vacuum vessel. The NB cell will form the secondary confinement barrier.

The Figure 1 shows the NB-Cell including the 3 HNBS and the DNB.

The Figure 2 shows a Top view of the HNB1 and HNB2 connected to the VVPSS line of ITER.

*Figure 1: Isometric view of the NB-Cell*

SUPPLY

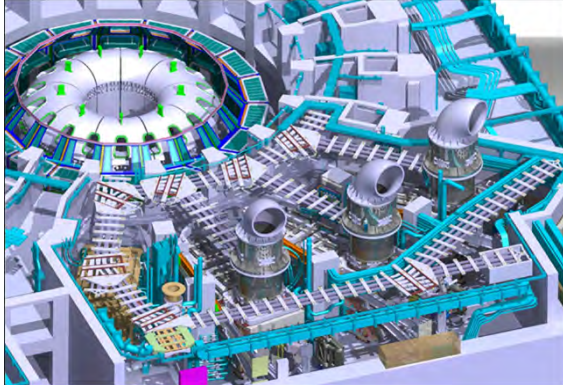
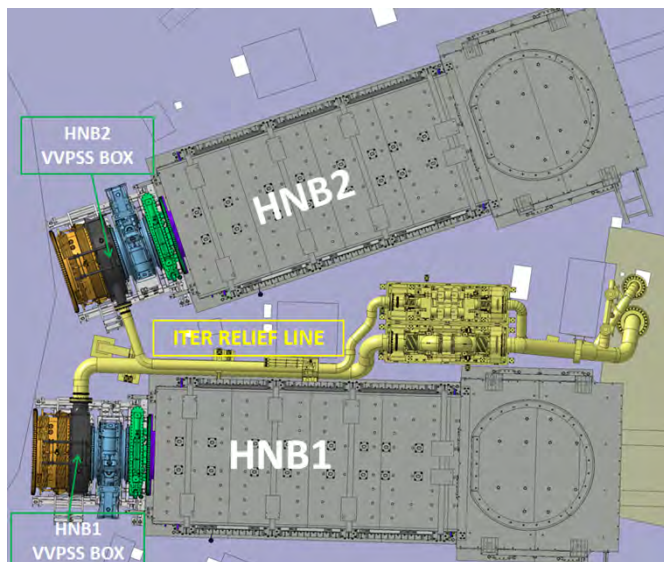

Figure 2: Top view of VVPSS line in the NB Cell configuration PFPO1



[53\_IO\_NB\_VVPSSBT- INFO 20] The VVPSS Boxes (HNB1 & HNB2) are part of the ITER primary confinement boundary. It is located in the NB cell (L1) in the Tokamak building (see figure 2).

Figure 3: VVPSS Boxes HNB1 and HNB2 in configuration SRO

## SUPPLY

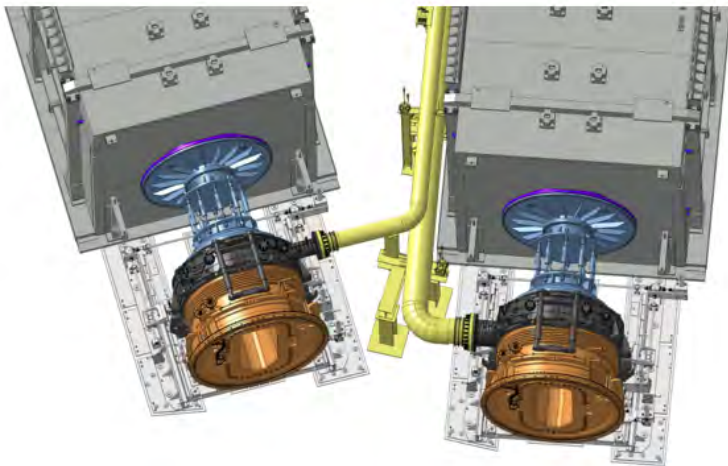

### 5.3.2 Functions of the VVPSS Boxes

[53\_IO\_NB\_VVPSSBT- INFO 21] The VVPSS boxes belongs to the batch of the NB Front end Components which connect the Vacuum Vessel to the NB Injector through Equatorial ports #4 and #5. The VVPSS boxes are implemented only the HNB1 and HNB2 lines.

The main functions of the VVPSS box are the following:

- to provide the primary vacuum containment for this section of the NB H&CD system
- to provide Low Loss flow pathway between VV and VVPSS
- to form part of Primary Vacuum boundary
- To interface the Absolute Valve

[53\_IO\_NB\_VVPSSBT- INFO 22] Some additional functional requirements can be summarised as follow

- Baking compatibility
- Vacuum compatibility
  - Vessel Body capable of sustaining differential pressure
  - Vacuum compatible materials
  - Vacuum compatible primary vacuum boundary interfaces
- Environmental compatibility
  - Neutron and secondary gamma irradiation
  - Chemical composition of the materials (Low Cobalt content)
  - Electromagnetic
- Installation & Removal
  - Fully Remote Handling compatibility
  - Accurate positioning interfaces

Figure 4: HNB1 VVPSS Box

**SUPPLY**



[53\_IO\_NB\_VVPSSBT- INFO 23] This component provides the primary vacuum containment for this section of the NB H&CD system and therefore provides a part of the first confinement barrier of the in-vessel radioactive inventory. This component is designed to be compatible with H0 and D0 beams.

[53\_IO\_NB\_VVPSSBT- INFO 24] The VVPSS box has been designed to operate from the D-D phase up to an active DT phase that lasts at least 14 years.

*5.3.3 Description of the VVPSS Box Items*

[53\_IO\_NB\_VVPSSBT- INFO 25] The VVPSS Box is located between the Drift Duct on the Vacuum Vessel (VV) side, and the Absolute Valve on the NB side. The position of the VVPSS box within the NB line is shown by figure 5.

*Figure 5: NB FEC connected to the NB Port*

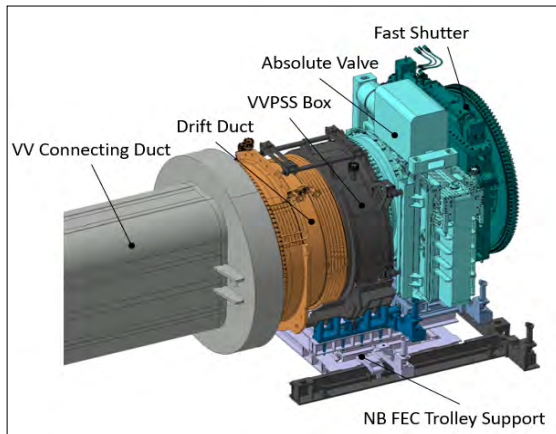

[53\_IO\_NB\_VVPSSBT- INFO 26] The Drift Duct procurement is not within the scope of this TS.

### SUPPLY

[53\_IO\_NB\_VVPSSBT- INFO 27] The weld between the DD and the VVPSS Box is an option of the scope of this Technical Specification – see section 5.5

Figure 6: General view of the DD with the VVPSS Box

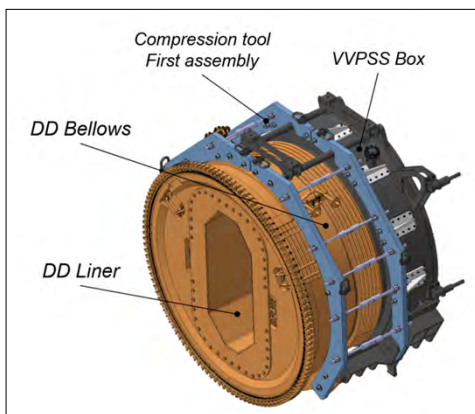

[53\_IO\_NB\_VVPSSBT- INFO 28] The HNB VVPSS Box and its Trolley presented at the FDR [66] is fully documented in the Design Description Report [59] and [61]. This TS will refer mainly to the section 7 of the document [59] for the detailed description of the components. FEA analysis are in [67].

[53\_IO\_NB\_VVPSSBT- INFO 29] The HNB VVPSS Box procurement consists of the following components:

- The VVPSS Box HNB1 [59] (VB1)
- The VVPSS box HNB2 [59] (VB2)
- The VVPSSB Trolley support (X2) [61] (VBT)
- The VVPSS Blanking Flange (X2) [59] (BF)
- The VVPSSB Anchor System (X2) [59] (AT)

[53\_IO\_NB\_VVPSSBT- INFO 30] All along this document the package of components listed just above will be called **VVPSS Box Items : VVPSSB-Is**

#### 5.3.3.1 HNB VVPSS Boxes description

##### 5.3.3.1.1 HNB1 VVPSS Box

[53\_IO\_NB\_VVPSSBT- INFO 31] Detailed description of the HNB1 VVPSS Box (figure 7) is documented in section 5 of the Design Description Report [59].

[53\_IO\_NB\_VVPSSBT- INFO 32] The HNB1 VVPSS Box (figure 7) utilizes a DN500 pipe to connect to 3 VSTs (Large LOCA tanks in the DTR).

Figure 7: General views of HNB1 VVPSS Box (Interface DN500)

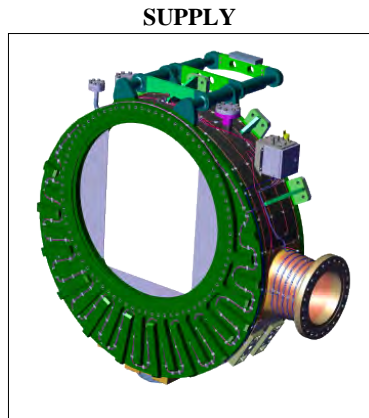

**5.3.3.1.2 HNB2 VVPSS Box**

[53\_IO\_NB\_VVPSSBT- INFO 33] Detailed description of the HNB2 VVPSS Box (figure 8) is documented in section 5 of the Design Description Report [59].

[53\_IO\_NB\_VVPSSBT- INFO 34] The HNB2 VVPSS Box (figure 8) utilizes a DN300 pipe to connect to 3 VSTs (Large LOCA tanks in the DTR).

*Figure 8: General views of HNB2 VVPSS Box (interface DN300)*

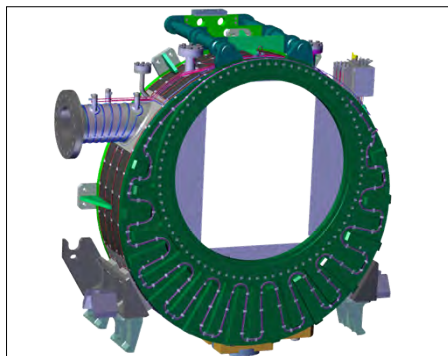

**5.3.3.2 VVPSS box Trolley Support**

[53\_IO\_NB\_VVPSSBT- INFO 35] Detailed description of the VVPSS Box Trolley support (figure 9) is documented in the Design Description Report [61].

*Figure 9: General view of The VVPSS box Trolley support*

**SUPPLY**

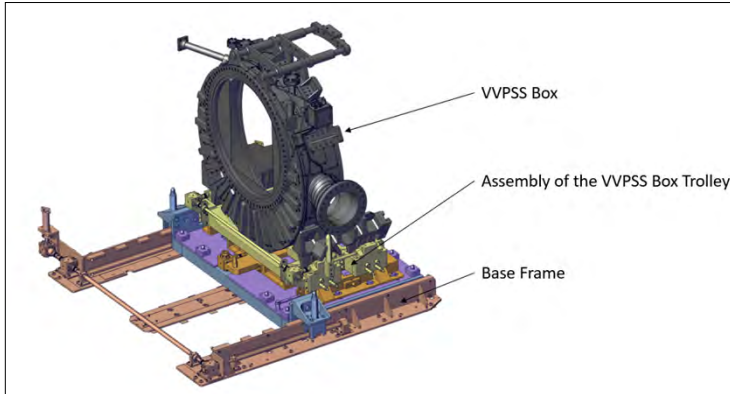

**5.3.3.3 VVPSS box Blank Flange**

[53\_IO\_NB\_VVPSSBT- INFO 36] Detailed description of the VVPSS Box Blank flange (figure 10) is documented in section 6.1.3 of the Design Description Report [59].

*Figure 10: General view of The VVPSS box Blank Flange*



**5.3.3.4 VVPSS box Anchor System**

[53\_IO\_NB\_VVPSSBT- INFO 37] Detailed description of the VVPSS Box Anchor System (figure 11) is documented in section 6.1.3 of the Design Description Report [59].

**SUPPLY**

Figure 11: General view of The VVPSS box Anchor System

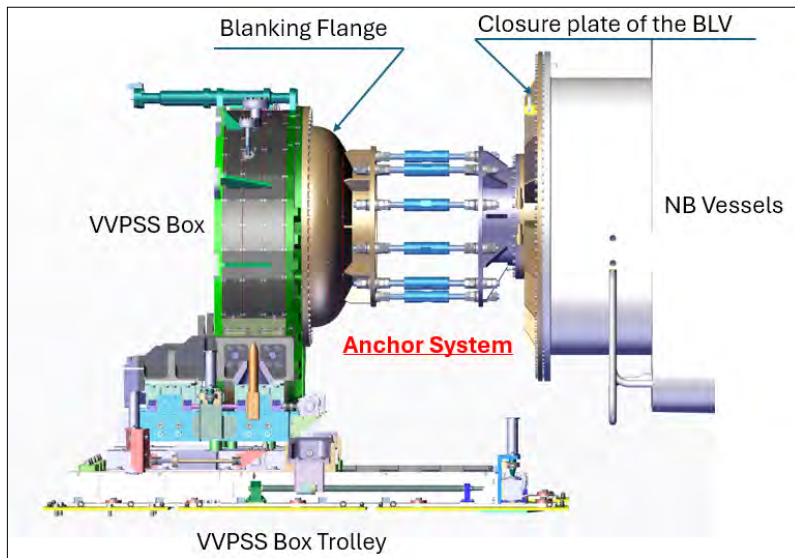

**5.3.3.5 Baking and I&C system of the VVPSS Box description**

[53\_IO\_NB\_VVPSSBT- INFO 38] A detailed description of I&C feedthroughs (figure 12)of the DD is documented in section 5.6 of the Design Description Report [59].

Figure 12: General views of Baking and I&C system of the VVPSS box

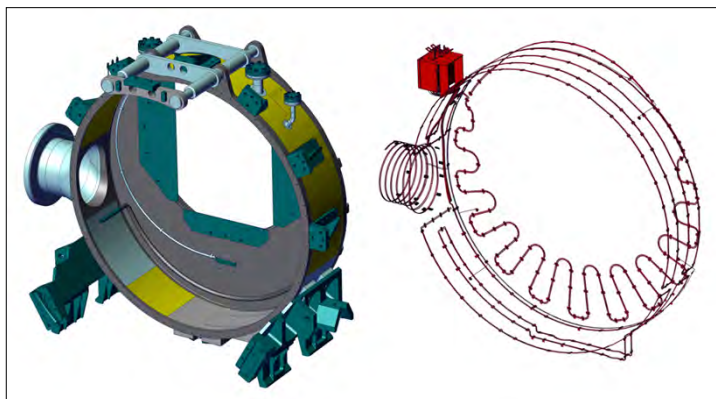

**5.3.4 Classification of the VVPSS Box Items**

**SUPPLY**

[53\_IO\_NB\_VVPSSBT- INFO 39] Table 2 and 3 indicate the classification of the VVPSS Box components in accordance with the ITER classification system (VQC class, SIC class...).

Table 2 Classifications (I) of the VVPSS Box

	First Confinement	Safety Class.	Quality Class.	Vacuum Class.	Design code	Manufacturing code
<b>VVPSS Boxes (HNB1 &amp; HNB2)</b>	Yes	<b>SIC 1</b>	QC-1	VQC-1A	RCC-MR 2007 class 2	RCC-MR 2007 Class 2
<b>SVS piping</b>	Yes	SIC 2	QC 1	VQC-3A	NA	NA
<b>Blanking flange (SRO configuration)</b>	Yes	<b>SIC 1</b>	QC-1	VQC-1A	RCC-MR 2007 class 2	RCC-MR 2007 Class 2
<b>Anchor System (SRO configuration)</b>	No	<b>SIC 2</b>	QC-1	NA	RCC-MR 2007 class 2	RCC-MR 2007 Class 2

Table 3 Classifications (II) of the VVPSS Box

	PED Class	ESPN Nuclear level	Seismic Class	Tritium class	RH class
<b>VVPSS Boxes</b>	N/A	N/A	1(S)	1A	RH Class 3
<b>Blanking flange (SRO configuration)</b>	N/A	N/A	1(S)	N/A	NA
<b>Anchor System (SRO configuration)</b>	N/A	N/A	1(S)	N/A	NA
<b>Closure Plate</b>	N/A	N/A	N/A	N/A	NA

Table 4 Classifications (I) of the VVPSS Boxes (HNB1 & HNB2)

	First Confinement	Safety Class.	Quality Class.	Vacuum Class.	Design code	Manufacturing code
<b>Base Frame</b>	No	SIC 2	QC 2	NA	RCC-MR 2007 code Volume H	RCC-MR 2007 code Volume H
<b>Trolley VVPSSB Tx</b>	No	SIC 2	QC 2	NA	RCC-MR 2007 code Volume H	RCC-MR 2007 code Volume H
<b>Interface Plate set</b>	No	SIC 2	QC 2	NA	RCC-MR 2007 code Volume H	RCC-MR 2007 code Volume H

**SUPPLY**

	First Confinement	Safety Class.	Quality Class.	Vacuum Class.	Design code	Manufacturing code
<b>Setting Frame (Rx,Ty)</b>	No	SIC 2	QC 2	NA	RCC-MR 2007 code Volume H	RCC-MR 2007 code Volume H
<b>Tz Mobile Frame</b>	No	SIC 2	QC 2	NA	RCC-MR 2007 code Volume H	RCC-MR 2007 code Volume H

Table 5 Classifications (II) of the DD

	PED Class	ESPN Nuclear level	Seismic Class	Tritium class [8]	RH class
<b>Base Frame</b>	N/A	N/A	SC-1(SF)	1A	NA
<b>Trolley VVPSSB Tx</b>	N/A	N/A	SC-1(SF)	1A	NA
<b>Interface Plate set</b>	N/A	N/A	SC-1(SF)	1A	RH Class 3
<b>Setting Frame (Rx,Ty)</b>	N/A	N/A	SC-1(SF)	1A	RH Class 3
<b>Tz Mobile Frame</b>	N/A	N/A	SC-1(SF)	1A	RH Class 3

**5.3.5 General Technical Interfaces**

[53\_IO\_NB\_VVPSSBT- INFO 40] The FDR of the HNB VVPSS Box Items has been held the 24<sup>th</sup> November 2024.

[53\_IO\_NB\_VVPSSBT- INFO 41] The VVPSS Box Items design fulfils all technical interfaces requirements.

[53\_IO\_NB\_VVPSSBT- INFO 42] The Build To Print 2D drawings are listed in the Bills of Material [17] & [18]. These 2D drawings reflect the design presented to the FDR and include the geometrical requirements to fulfil regarding these interfaces.

[53\_IO\_NB\_VVPSSBT- INFO 43] The HNB VVPSS Box is in interface with the Drift Duct and the Absolute Valve. These interfaces are described in section 6.1.1 & 6.1.2 of the Design Report [59] which reflects the design of the component at Final Design maturity.

[53\_IO\_NB\_VVPSSBT- INFO 44] The VVPSS Box has been designed to be compliant with following interfaces:

- Drift Duct (PBS 53)
- Absolute Valve (PBS53)
- Remote Handling Tool (PBS 23)
- Assembly Tool (PBS53)
- I&C (for the TC and Heating Elements)

**SUPPLY**

[53\_IO\_NB\_VVPSSBT-R 010] The manufacturer shall respect the Geometrical interfaces defined by their dimensions and functional tolerances in the Built To Print Drawings [17] & [18].

**5.4 WBS**

[53\_IO\_NB\_VVPSSBT- INFO 45] The supply will be organised according to the following top-level Work Breakdown Structure (WBS) that identifies groups of activities called Work Package (WP) with correspondent milestones and deliverables (see Section 23 for milestones and deliverables).

*Table 6 Top level WBS of the project*

Phase	CODE	Drawing number and title
0	PM	Project management, Quality and Nuclear Safety
1	E	Engineering
2	Q	Qualifications and factory preparation
3	P	Procurement (raw material and sub-contracting)
4	M	Manufacturing
5	T	Factory Acceptance
6	D	Transport and Delivery
7	S	Site acceptance tests and Final acceptance

[53\_IO\_NB\_VVPSSBT- INFO 46] Note: the phases in the WBS may apply to all or to some components from Table 1.

[53\_IO\_NB\_VVPSSBT- INFO 47] Please note that in the Supplier schedule the engineering and qualification activities may be common for all VVPSS BOX Items deliveries, subject to Supplier’s delivery organisation.

[53\_IO\_NB\_VVPSSBT- INFO 48] As indicated in the scope requirements the Supplier will allocate manufacturing, factory acceptance tests and delivery activities of each component under the VVPSS BOX Items project in the Supplier schedule.

[53\_IO\_NB\_VVPSSBT- INFO 49] The Supplier may plan the activities foreseen for different WPs in parallel if convenient for scheduling reasons but subjected to IO approval before implementation.

[53\_IO\_NB\_VVPSSBT-R 011] The Supplier shall request written approval of IO to start activities of each WP (with the exception of the WP\_PM0).

[53\_IO\_NB\_VVPSSBT-R 012] The Supplier shall adopt the following structure for description, planning and organization of the work to be carried out. The Supplier shall integrate the proposed WBS as applicable:

- WP\_PM0 – Project management and Quality
- WP\_E1 – Engineering
- WP\_Q2 – Qualifications and factory preparation
- WP\_P3 – Procurement
- WP\_M4 – Manufacturing
- WP\_T5 – Factory Acceptance Testing
- WP\_D6 –Packing, Transport and Delivery

## SUPPLY

WP\_S7 – Site acceptance tests and Final acceptance Options

[53\_IO\_NB\_VVPSSBT-R 013] The Supplier shall further detail and develop the proposed top level WBS.

[53\_IO\_NB\_VVPSSBT-R 014] The Supplier shall provide at KOM a WBS dictionary (description of content with top level and top level-1 described) in accordance with the developed WBS. The Supplier may propose improvements in activity allocation among WPs for IO acceptance.

### 5.4.1 WP\_PM0 – Project management, Quality, and Nuclear Safety

[53\_IO\_NB\_VVPSSBT- INFO 50] This Work Package comprises all the efforts related to the timely and appropriate management of the project activities, quality, safety, documentation management, Supplier performance, contract performance and reporting execution as well as planning. The WP includes management of subcontractors.

### 5.4.2 WP\_E1 – Engineering

[53\_IO\_NB\_VVPSSBT- INFO 51] This Work Package comprises all the engineering activities related to the production of the design, plans, procedures, drawings and documents necessary for the Procurement, Purchase, Qualification, Manufacturing and Factory acceptance testing for the DD that are performed in the following WPs: Q2, P3, M4, T5.

### 5.4.3 WP\_Q2 – Qualifications and factory preparation

[53\_IO\_NB\_VVPSSBT- INFO 52] The WP comprises all the qualification and factory preparation activities and includes:

- Qualification and acceptance of the special processes required for DD manufacturing.
- Preparation of adequate workshop areas, final clean condition workshop area, storage, accepted materials, fluids, consumables and other scope specific facility/equipment preparations (e.g. jigs and handling tools).
- Qualification for NDE and welding personnel, as applicable.
- Planning for the NDE and metrology tools and facilities.

### 5.4.4 WP\_P3 – Procurement

[53\_IO\_NB\_VVPSSBT- INFO 53] The activities of this WP can start only after the completion of respective procurement related activities in WP\_E1 and with written agreement by IO.

The WP includes all materials needed for VVPSS Boxes and Trolleys delivery condition specified in BtP package and material needed for construction and testing.

[53\_IO\_NB\_VVPSSBT- INFO 54] This WP includes also material procurement qualifications (e.g. procurer, sub-contractors, product) as well as all the activities necessary for qualification of factories and sub-contractors.

[53\_IO\_NB\_VVPSSBT-R 015] The Supplier shall carry out all the activities necessary for purchase, procurement, acceptance and delivery of the base materials, filler material and off-the-shelf components of the VVPSS Box Items.

## SUPPLY

### 5.4.5 WP\_M4 – Manufacturing

[53\_IO\_NB\_VVPSSBT- INFO 55] The activities of this WP can start upon approval by IO of the Manufacturing Readiness Review unless otherwise agreed in writing with IO.

The work package includes manufacturing activities quality control, assembly and testing of the VVPSS Box Items (HNB1 & HNB2) before the start of the FAT.

### 5.4.6 WP\_T5 – Factory Acceptance Testing

[53\_IO\_NB\_VVPSSBT- INFO 56] This Work Package shall comprise the preparation and execution of the factory acceptance tests and additional tests of the VVPSS Box Items (HNB1 & HNB2).

[53\_IO\_NB\_VVPSSBT- INFO 57] Additional tests for which VVPSS Box Items (HNB1 & HNB2) like for instance the VVPSSB Trolley are needed should be done outside equipment delivery schedule critical path where possible or following a sequence subject to IO approval.

[53\_IO\_NB\_VVPSSBT-R 016] The exact content of the FAT will be detailed in the FAT plan which shall be approved by IO.

[53\_IO\_NB\_VVPSSBT- INFO 58] The FAT includes the tests specified in section 7.1.2.1.3

### 5.4.7 WP\_D6 – Packing, Transport and Delivery

[53\_IO\_NB\_VVPSSBT- INFO 59] This Work Package comprises all the activities related to the production of the design and manufacturing of transportation equipment, as well as packing, plans, procedures, drawings and documents necessary for the intermediate and final transport of the components.

The WP includes, but is not limited to:

- Procurement/fabrication of Transportation equipment and special lifting equipment.
- Preparation of all documentation necessary.
- Cleanliness check, packing and temporary storage.
- Intermediate transport.
- Transport and delivery to ITER site.

### 5.4.8 WP\_S7 - Site Acceptance Tests and Final acceptance.

[53\_IO\_NB\_VVPSSBT- INFO 60] This Work Package comprises all the activities related to the Site acceptance test activities and final acceptance of the components and services to be delivered.

## 5.5 Option: Welding the VVPSS box to the Drift Duct

### 5.5.1 Description of the interface

[53\_IO\_NB\_VVPSSBT- INFO 61] The VVPSS Box and the Drift Duct are classified as level 2 box structure type, with a supporting and sealing function. VVPSS Box and Drift Duct have the same function of first Confinement and Vacuum Boundary. They are connected to NB Port.

[53\_IO\_NB\_VVPSSBT- INFO 62] These 2 components needs to be welded together according to the RCC-MRX code.

[53\_IO\_NB\_VVPSSBT- INFO 63] The interface is 2 flanges made in X2CrNiMo17-12-2

**SUPPLY**

[53\_IO\_NB\_VVPSSBT- INFO 64] Following this classification, RC 3800 “chamber structural design rules” [2] will be mainly apply to justify the welds; the welding analysis shall consider all of these requirements.

[53\_IO\_NB\_VVPSSBT- INFO 65] Annex A19 of RCC-MR [1] specifies features for ITER vacuum chamber. In addition, the ITER Vacuum Handbook specifies particular points concerning welds and examinations of them for vacuum items [5].

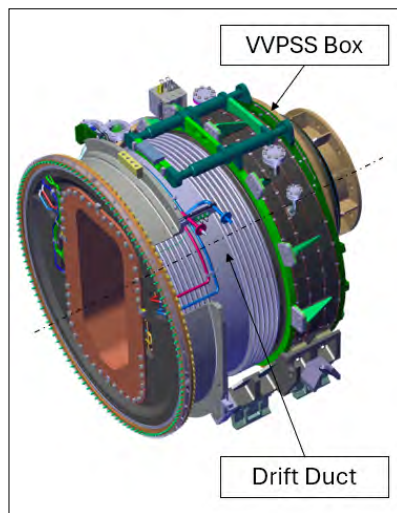

Figure 13 : Batch VVPSS Box Welded to the Drift Duct

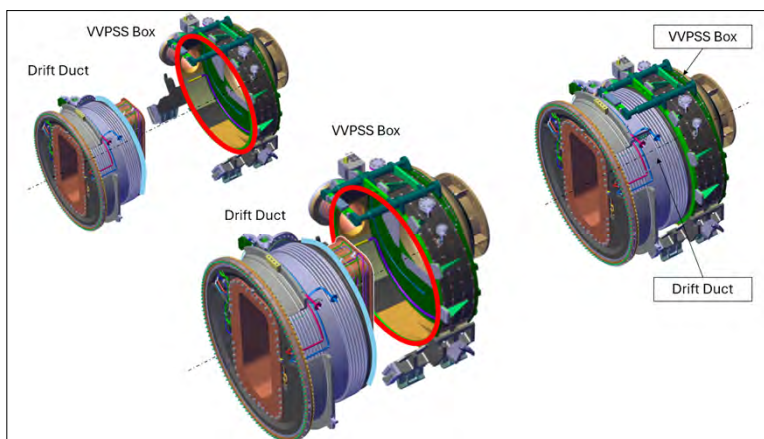

Figure 14 : Batch VVPSS Box Welded to the Drift Duct

[53\_IO\_NB\_VVPSSBT- INFO 66] The welded interface between the DD and the VVPSS Box has been design according to the RCC-MRX code with the following classification:

- The welded assembly category
- The welded joint type

## SUPPLY

[53\_IO\_NB\_VVPSSBT- INFO 67] In addition to the RC 3800 (for box structures), Annex A19 (Specifications for ITER Vacuum Chamber) [1] is considered.

[53\_IO\_NB\_VVPSSBT- INFO 68] We must consider that there is no double wall: the DD and the VVPSS box are composed of the wall being the internal shell stiffened by welded stiffeners, so that no external shell are defined.

[53\_IO\_NB\_VVPSSBT- INFO 69] In conclusion, it was proposed to refer to the A19, RC 3800 and RC 3600 [5] to perform the classification of welds. The ITER Vacuum Handbook [6] is also used as the component (and welds), which is a vacuum component, shall also be compliant with.

[53\_IO\_NB\_VVPSSBT-R 017] According to RC 3833.3 [1], the welded interface between the DD and the VVPSS Box shall be category 1

[53\_IO\_NB\_VVPSSBT-R 018] According to RCC-MRX vol C&D in the table RC 3851 [1], the welded interface between the DD and the VVPSS Box shall have a joint coefficient 1.

[53\_IO\_NB\_VVPSSBT-R 019] The contractor shall define the full design bevel between the two components (2D drawing).

[53\_IO\_NB\_VVPSSBT-R 020] The contractor shall define the full sequence of welding operations.

[53\_IO\_NB\_VVPSSBT-R 021] The contractor shall define the tools and welding technology to be used and justify the feasibility for the access.

[53\_IO\_NB\_VVPSSBT- INFO 70] The contractor is free to propose any alternative of:

- the design of the welding interface taking into account the RCC-MR Criteria.
- The manufacturing sequence of the VVPSS Box welded assembly.

### 5.5.2 Overview

[53\_IO\_NB\_VVPSSBT-R 022] The supplier shall perform the welding of the DD to the VVPSS Box on his premises.

[53\_IO\_NB\_VVPSSBT- INFO 71] In order to perform those activities, IO will free issue to the supplier:

- The DD mounted on its support,
- Any equipment necessary to close the apertures of the DD, in order to enable the performance of the Leak Test.

[53\_IO\_NB\_VVPSSBT- INFO 72] Those free issued items are detailed in section 11.

### SUPPLY

[53\_IO\_NB\_VVPSSBT-R 023] Upon release of the option which shall not be later than the date of Final Acceptance of the VVPSS Box , the Supplier shall prepare a manufacturing plan for the welding at site, and upon agreed timing with IO, perform fit-up verification, perform welding and consequent NDE of the welds, as well as the final leak test of the assembly at the place of delivery as specified.

[53\_IO\_NB\_VVPSSBT-R 024] The option shall include all equipment, materials, consumables, services and personnel needed to complete the welds such as (non/exhaustive):

- Site activity preparation
- Issue of applicable procedures and site documentation
- Performance of DD and VVPSS Box final installation activities important for fit-up (handling and fit-up activities are in the scope of OPTION 2).
- Cleaning protection/segregation of the weld perimeter from other surfaces.
- Qualification of the welding operations.
- Welding and NDE of the weld between the DD and the VVPSS BOX
- Dimensional inspection after welding
- Final cleaning of the weld and weld perimeter.
- Performance of the DD/VVPSS Box Assembly leak test
- Weld repair activities due to NDE or leak test observations.

[53\_IO\_NB\_VVPSSBT-R 025] The Supplier shall provide the Cost Breakdown Structure for the option with the tender offer.

[53\_IO\_NB\_VVPSSBT-R 026] The supplier shall provide the schedule for the option activities performed by the Supplier.

[53\_IO\_NB\_VVPSSBT-R 027] The supplier shall quote the following services:

- Technical documentation preparation for the site activities.
- Activities to be performed at the place of delivery:
  - Incoming inspection of the free issued items
  - Fit up of the DD with the VVPSS Box (DD/VVPSS Box handling and fit up are in the scope of option 2)
  - Dimensional inspection after Fit-up to verify fitness for welding
  - Protection of the weld perimeter from spread of contamination due to site welding activity.
  - Welding preparatory activities (NDE etc. as required by [1] class 2)
  - Welding of the joint
  - NDE (100% RT is requested) of the welded joints
  - Dimensional inspection after welding
  - Final cleaning of the weld perimeter area
  - Leak test of the full assembly
- Preparation of an EMR of the site welding activity.

## SUPPLY

[53\_IO\_NB\_VVPSSBT-R 028] Upon the release of the option the Supplier shall become fully responsible of the overall DD/VVPSS Box weld joint and weld perimeter cleanliness subject to risk of contamination during supplier activities at the site.

### 5.5.3 Documentation

[53\_IO\_NB\_VVPSSBT-R 029] Before the manufacturing operations start, the supplier shall prepare and deliver to IO, for approval, the following documentation:

- The clean work plan and the list of manufacturing consumables
- The manufacturing and inspection plan,
- The welding documentation (Distortion management plan, WDP, WPS, WPQR, WQTR...),
- The NDE procedures,
- The material certificates (e.g. for the filler material),
- The procedure for the incoming inspection of the items free issued for the option
- The procedure for the installation and fit up on the DD with the VVPSS Box,
- The procedure for the inspection (dimensional, visual) of the correct assembly before welding,
- The cleaning and cleanliness test procedures,
- The procedure for the leak test after welding,
- The documentation related to the dimensional inspection after welding related to the operations under the scope of the Option

[53\_IO\_NB\_VVPSSBT-R 030] After manufacturing, the supplier shall prepare and deliver to IO, for approval, the following documentation:

- The manufacturing and inspection plan (filled in),
- The as built welding documentation (WDP, WPS, WPQR, WQTR, production weld datasheet...),
- The NDE records,
- The RT films (physical delivery to ITER site),
- The material certificates (e.g. for the filler material),
- The report on the incoming inspection of the items free issued for option 2 (see section 11),
- The report for the inspection after installation and fit up on the DD with the VVPSS Box,
- The report on the cleanliness test after manufacturing,
- The report for the leak test after welding,
- NCRs, if any.

[53\_IO\_NB\_VVPSSBT-R 031] The Supplier shall provide to IO an EMR compiling all the documentation to be delivered before and after manufacturing.

**SUPPLY**

5.5.4 – Study

[53\_IO\_NB\_VVPSSBT- INFO 73] The welding interfaces on the DD side are on the DD-VVPSS Box flange.

[53\_IO\_NB\_VVPSSBT- INFO 74] The welding of the DD to the VVPSS Box is illustrated on Figure15.

Figure 15: Interface between the DD & VVPSS Box

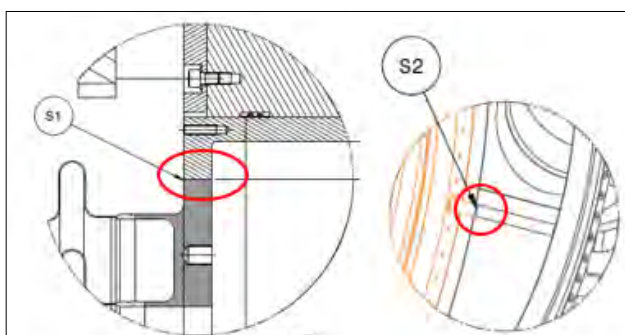

[53\_IO\_NB\_VVPSSBT- INFO 75] These welds are classified as follows in accordance with table RC3833.3a [1] (Class 2 equipment, box structures) :

- Weld S1: category 1 type I.1
- Wels S2: category 1 type II.1.

[53\_IO\_NB\_VVPSSBT- INFO 76] A study of the welding procedure between the components has been carried out and demonstrate the feasibility of the weld; guidance ad recommendations are provided in this document [79].

[53\_IO\_NB\_VVPSSBT-R 032] The supplier shall define in the manufacturing drawings, part of the MRR (item 12 of table 7) for IO approval, the welded interface and tolerances between the Drift-Duct and the NB VVPSS-Box according to assembly drawing [76].

[53\_IO\_NB\_VVPSSBT-R 033] The butt weld geometry (the bevel) between Drift-Duct and NB VVPSS-Box shall be studied, analysed in term of weldability, distortion, NDE control and defined (including the bevel geometry) in the manufacturing drawings of the Drift-Duct.

[53\_IO\_NB\_VVPSSBT-R 034] The butt weld geometry (the bevel) between Drift-Duct and NB VVPSS-Box defined by the supplier shall ensure that a full penetration butt weld can be performed.

### SUPPLY

- [53\_IO\_NB\_VVPSSBT-R 035] The design of the Drift-Duct and the VVPSS box, designed by IO, ensures the necessary access for 100% radiography of the weld. The supplier shall ensure that the butt weld geometry (the bevel) between Drift-Duct and NB VVPSS-Box defined by the supplier can be 100% radiographed.
- [53\_IO\_NB\_VVPSSBT-R 036] A report shall be provided, for IO approval, on the study of the geometry (the bevel on both components) chosen for the weld (not in the scope of this TS) between the Drift-Duct and NB VVPSS-Box.

#### 5.5.5 Manufacturing and testing operations

##### **Important:**

- [53\_IO\_NB\_VVPSSBT-R 037] The activities related to welding qualification shall be under the responsibility of the supplier, under the scope of the option.
- [53\_IO\_NB\_VVPSSBT-R 038] The activities related to option 2 shall be performed in a clean area.
- [53\_IO\_NB\_VVPSSBT-R 039] The supplier shall install and fit up the DD with the VVPSS box in accordance with the approved procedure.
- [53\_IO\_NB\_VVPSSBT-R 040] Before welding, the supplier shall perform a visual and dimensional inspection of the DD - VVPSS box in accordance with the approved procedure.
- [53\_IO\_NB\_VVPSSBT-R 041] The supplier shall weld the DD to the VVPSS box in accordance with the requirements from section 6.7.
- [53\_IO\_NB\_VVPSSBT-R 042] After welding, the supplier shall perform a dimensional inspection of the assembly in accordance with section 6.14
- [53\_IO\_NB\_VVPSSBT-R 043] After welding, the supplier shall clean the components in accordance with the requirements from section 8.
- [53\_IO\_NB\_VVPSSBT-R 044] After welding, the supplier shall perform a cleanliness test in accordance with section 8.4 on the components.
- [53\_IO\_NB\_VVPSSBT-R 045] After welding, the supplier shall perform a leak test of all the components in accordance with section 7.1.3.6.
- [53\_IO\_NB\_VVPSSBT-R 046] This leak test includes testing the welds S1 and S2 as specified on Figure 15, and will require pumping the full volume of the DD-VVPSS Box assembly under vacuum.
- [53\_IO\_NB\_VVPSSBT-R 047] The maximum acceptable leak rate of the DD/VVPSS Box assembly shall be less than  $1 \times 10^{-9}$  Pa.m<sup>3</sup>/s air equivalent.

## SUPPLY

### 5.5.6 Acceptance of OPTION

[53\_IO\_NB\_VVPSSBT- INFO 77] Acceptance of the completed Filled-in CP and ready for EMR in IO system is the proof of acceptance of the option.

## 5.6 CAD Models

[53\_IO\_NB\_VVPSSBT- INFO 78] The CAD model is referenced in ENOVIA at the location shown on the Figure 16.

Figure 16: CATIA Model

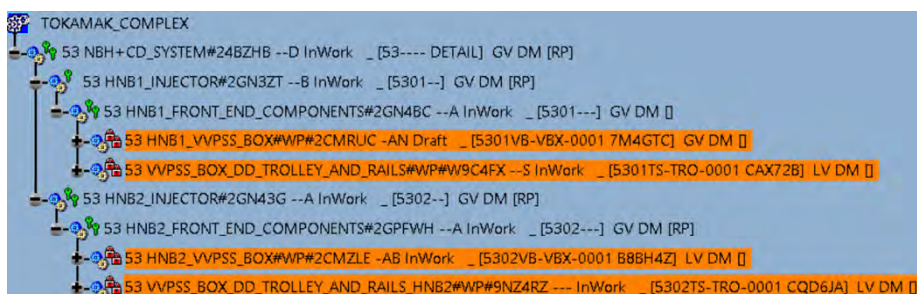

## 5.7 Scope of Contract

### 5.7.1 Related activities

[53\_IO\_NB\_VVPSSBT- INFO 79] The IO is responsible to provide the Build To Print package to the manufacturer in line with a design maturity up to a FDR level.

[53\_IO\_NB\_VVPSSBT- INFO 80] The IO was responsible for carrying out the complete design, in compliance with the requirements as defined in related documents (SRD [51], LS[4]...) and in line with the Design Review, starting from Conceptual Design, through Preliminary design and up to Final Design. As such, IO is the manufacturer in terms of Equipment Safety (nuclear and non-nuclear) and will be responsible for the CE marking with the exception of the specific tools.

[53\_IO\_NB\_VVPSSBT-R 048] The procurement of the HNB VVPSS Box shall consist in the procurement and the delivery of the two HNB VVPSS Boxes, two blank flanges, two anchor systems and two VVPSSB Trolley as defined in [17] & [18] for the injectors HNB#1 and HNB#2.

[53\_IO\_NB\_VVPSSBT-R 049] Based on Build To Print documentation provided by IO, the manufacturer shall demonstrate that the related acceptance criteria are met.

[53\_IO\_NB\_VVPSSBT-R 050] The manufacturer shall provide the components manufactured in compliance with the requirements defined in the present document.

## SUPPLY

[53\_IO\_NB\_VVPSSBT-R 051] The manufacturer shall provide the procedures or technical descriptions for the FAT tests, for the inspections, for the examinations and for the transport (delivery transport description), etc. requested in this TS.

[53\_IO\_NB\_VVPSSBT-R 052] The manufacturer shall provide the “as-built” 2D drawings after dimensional survey of the components manufactured.

### 5.7.2 *Manufacture of the Component*

[53\_IO\_NB\_VVPSSBT-R 053] The manufacturing plan to be performed by the manufacturer shall include the procurement of the material specified according to the material specification (section 6.4);

[53\_IO\_NB\_VVPSSBT-R 054] The manufacturing activities to be performed by the manufacturer as cutting, forming, welding, inspections, cleaning shall follow the requirements from section 7;

[53\_IO\_NB\_VVPSSBT-R 055] The manufacturing plan to be performed by the manufacturer shall include the testing in compliance with the requirements defined in section 7,

[53\_IO\_NB\_VVPSSBT-R 056] The manufacturing plan to be performed by the manufacturer shall include the design and manufacturing of the specific tools required for the manufacturing and testing of the component;

[53\_IO\_NB\_VVPSSBT-R 057] For these specific tools the manufacturer or its Contractors shall be the manufacturer in terms of Equipment Safety and shall be responsible for the CE marking.

[53\_IO\_NB\_VVPSSBT-R 058] The manufacturer scope shall include the factory acceptance tests prior to packing and shipment.

[53\_IO\_NB\_VVPSSBT-R 059] The manufacturer’s scope shall include the transportation to the ITER site of all the components including any specific tools, supports and fittings used for the factory leak test.

[53\_IO\_NB\_VVPSSBT- INFO 81] Equipment needed for the fabrication and factory tests, not listed in the BoM, that are available off the shelf like for instance pumps and leak detectors needed for the leak tests are not required to be delivered.

### 5.7.3 *Design change Post FDR.*

[53\_IO\_NB\_VVPSSBT-R 060] In case of design modification proposed by the manufacturer, that will change the 3D geometry, the manufacturer shall check that the design still withstands all loads defined in the Load Specification [4].

[53\_IO\_NB\_VVPSSBT-R 061] In case of design modification proposed by the manufacturer that will change the 3D geometry, it shall be submitted to IO for acceptance.

## SUPPLY

### 5.7.4 Documentation

[53\_IO\_NB\_VVPSSBT-R 062] The manufacturer shall provide IO with the documents and data defined in the Appendix 1 of this document: "List of the manufacturer deliverables"

#### 5.7.4.1 FDR

[53\_IO\_NB\_VVPSSBT- INFO 82] With this This TS, IO delivers to the manufacturer Build to Print documents coming from the FDR results. Based on this Build to Print package documentation, the manufacturer will be able to launch the next phases like contract phase, MRR, qualification phase, manufacturing phase, FAT and delivery of the component.

#### 5.7.4.2 Manufacturing Readiness Review (MRR)

[53\_IO\_NB\_VVPSSBT- INFO 83] A Manufacturing Readiness Review (MRR) consists in a set of source verification activities to be performed before fabrication in order to provide confidence that the manufacturing processes and activities, such as fabrication, storage, handling, shipping of product, will be adequately and effectively performed.

[53\_IO\_NB\_VVPSSBT- INFO 84] The MRR may be split in Delta MRRs allowing gradual acceptance of initiation of procurement and manufacturing activities, in particular for long lead time equipment. Organisation of the MRR will be discussed and agreed at KOM.

[53\_IO\_NB\_VVPSSBT- INFO 85] The last Review before manufacturing is the Manufacturing Readiness Review (MRR) that gives the go-ahead for the manufacturing of the components.

[53\_IO\_NB\_VVPSSBT- INFO 86] The MRRs related to the components listed in Table 7 may be held separately. Those milestones are identified separately in the milestones list (see appendix II):

- **E1.VB1-7** – MRR approved for VVPSS Box HNB1
- **E1.VB2-7** – MRR approved for VVPSS Box HNB2
- **E1.VBT-7** – MRR approved for VVPSS Box Trolley
- **E1.BF-7** – MRR approved for Blank Flange
- **E1.AS-7** – MRR approved for Anchor System
- **E1.OTH-7** – MRR approved for Other components

[53\_IO\_NB\_VVPSSBT-R 063] As described in [62], any manufacturing activity shall be authorized by a MRR.

[53\_IO\_NB\_VVPSSBT- INFO 87] Nevertheless, as clarified with the manufacturer systems engineering team, some activities such as material procurement, qualification, prototyping, etc... may start before an MRR is performed, provided the associated document (such as the Purchase Order Specification for example regarding material procurement) is accepted by IO.

[53\_IO\_NB\_VVPSSBT-R 064] The manufacturer shall be responsible for preparation, implementation, and follow-up action of MRR.

[53\_IO\_NB\_VVPSSBT-R 065] The manufacturer shall prepare a MRR Plan.

**SUPPLY**

- [53\_IO\_NB\_VVPSSBT-R 066] The manufacturer shall designate a chair for each MRR panel and organize the MRR panels.
- [53\_IO\_NB\_VVPSSBT-R 067] The manufacturer shall organize the MRR meetings.
- [53\_IO\_NB\_VVPSSBT-R 068] The manufacturer shall prepare the MRR Reports.
- [53\_IO\_NB\_VVPSSBT-R 069] The documents listed in table [5] shall be presented.
- [53\_IO\_NB\_VVPSSBT-R 070] during the MRR meetings. The annex I provides more details of the expected information to be provided in the MRR.

Table 7 List of documents to be provided at the MRR

ITEM	WBS	Title of Document	Status (at MRR meeting)	Action (for the panel members) at MRR / Comments
1	WP_E1	Engineering Analysis Reports (provided at FDR)	Approved	For reference, consulted, IO provided input for Supplier
2	WP_E1	Final Design Report Chit status report (Category I)	Approved	
3	WP_E1	Final Design Review Chit status report (Category II)	Approved	
4	WP_E1	3D models (DET) [74]	Approved	Applicable documents, consulted, IO provided input for Supplier
5	WP_E1	2D drawings [17][18]	Approved	
6	WP_E1	Component part list (Contractual Drawings) [17][18]	Approved	
7	WP_PM0	Deviations / PCR IF ANY	Approved	Consulted
8	WP_E1	Interface Sheets (FDR status)	Approved	For reference, consulted, IO provided input for Supplier
9	WP_E1	Purchase Order Specification for based material and filler material Material Specifications	Approved	Supplier output, consulted
10	WP_PM0	Supplier Quality Plan	Approved	Supplier output, consulted
11	WP_PM0	Contractor Supplier Risk management Plan	Approved	Supplier output, Reviewed
12	WP_E1	Manufacturing drawings	Provided	Supplier output, consulted
13	WP_M4	Material certificates	The document reference shall be provided	Supplier output, Reviewed
14	WP_E1	Fabrication shop / workshop detailed description for the complete assembly of the HNB Drift Duct <i>Note: The workshop qualification is part of the Quality Plan .</i> (The Main review should take place before MRR)	Provided	Supplier output, consulted
15	WP_E1	MIP (that included PIAs) for the HNB Drift Duct	Provided	Supplier output, Reviewed
16	WP_E1	Welding Data Package (WDP) <b>WPS / PQR/ WPQR</b>	Approved (recommended)	Supplier output, Reviewed
17	WP_E1	Distortion Management Plan	Provided	Supplier output, Reviewed
18	WP_E1	Non Destructive Examination (NDE) procedures	Provided	Supplier output, Reviewed

**SUPPLY**

19	WP_E1	Equipment identification, marking and traceability procedure. Material identification and Marking procedure	Provided	Supplier output, Reviewed
20	WP_E1	Dimensional checking procedure / Dimensional Control Plan (DCP)	Provided	Supplier output, Reviewed
21	WP_E1	Heat Treatment Procedure	Provided	Supplier output, Reviewed
22	WP_E1	Pickling and Passivation Procedure	Provided	Supplier output, Reviewed
23	WP_E1	Cleaning Procedure / Clean condition work plan	Provided	Supplier output, Reviewed
24	WP_E1	Leak Detection examination procedure Vacuum test procedure	Provided	Supplier output, Reviewed
25	WP_E1	Pressure test description and procedure	Provided	Supplier output, Reviewed
26	WP_E1	Packing procedure (for intermediate transport)	Provided	Supplier output, Reviewed
27	WP_E1	Storage procedure (for intermediate storage)	Provided	Supplier output, Reviewed
28	WP_E1	As Built 3D models when requested by IO (for the parts of the HNB Drift Duct covered by an NCR)	The document reference shall be provided	Supplier output documentation, will be reviewed when available at the relevant stage of the manufacturing
29	WP_E1	End of Manufacturing Report (EMR) Table of content for EMR to be defined and agreed	The document reference shall be provided	

Table 8 List of documentation to be provided during Technical review Milestone

TEM	WBS	Title of Document	Status (at MRR meeting)	Action (for the panel members) at MRR / Comments
30	WP_E1	Packing procedure	Approved	Supplier output, Reviewed
31	WP_E1	Storage procedure	Approved	Supplier output, Reviewed
32	WP_E1	Transportation procedure	Approved	Supplier output, Reviewed
33	WP_M4	As Built 3D models when requested by IO (for the parts of the HNB Drift Duct covered by an NCR)	Approved	Supplier output, Reviewed
34	WP_M4	As Built manufacturing 2D drawings	Approved	
35	WP_M4	End of Manufacturing Report (EMR) Table of content for EMR to be defined and agreed	Approved	
36	WP_T5	Leak and outgassing rate acceptance test report	Approved	Supplier output, Reviewed
37	WP_T5	Design Report and 2D drawings for the parts (jigs, tools, test bench, temporary thermocouples and additional temporary thermocouple feedthrough, heating elements, etc..) designed by Manufacturer	Approved	Supplier output, Reviewed
38	WP_E1	Analysis Reports for the parts (jigs, tools, test bench, temporary thermocouples and additional temporary thermocouple feedthrough, heating cables assemblies, etc.) designed by Manufacturer if needed.	Approved	Supplier output, Reviewed

**SUPPLY**

39	WP_T5	Outgassing rate acceptance test Procedure	Approved	Supplier output, Reviewed
40	WP_D6	Delivery description report	Approved	Supplier output, Reviewed

[53\_IO\_NB\_VVPSSBT- INFO 88] Nomenclature of IO Document Status (in IDM):

- Approved: Document approved in IO IDM.
- Reviewed: Documents or part of documents are in IO IDM under review.

[53\_IO\_NB\_VVPSSBT-R 071] Where document reference is required, it shall be provided with the Supplier document list (also forward looking) and other relevant references as applicable.

[53\_IO\_NB\_VVPSSBT-R 072] The Technical review milestone shall take place before the FAT.

[53\_IO\_NB\_VVPSSBT- INFO 89] As additional guidance for the welding preparation of the Manufacturing Readiness Review the manufacturer will address, complete and make available the following technical plans:

- Plan of welding drawings. The set of drawings, which provides welding information of welded joints in the assemblies: for example, the weld sequence to construct the assembly, welding direction, definition of front side and weld IDs mapped in the drawings.
  - Plan of Welding Procedure Specifications (WPS) to be applied for the welding of the HNB VVPSS Box, including supporting Welding Procedure Qualification Records, either qualified for the purpose (qualifications completed) or demonstration historical qualifications applicable for the scope. Synthesis of welding technical strategy for quality and performance.
  - Plan of Welding NDE to be applied and qualified for the manufacturing sequence of the VVPSS Box. Can be part of the NDE assessment prepared for the full scope of the delivery.
  - Detailed Weld book providing in a meaningful data set the welds definitions, bevel types or forms, base materials, references of the components, drawings, welding procedures and required NDEs. It is recommended that the weld book contains the reference of the applicable MIPs as well as a placeholder for NCR references.
  - Weld plan. The weld plan is formed of a set of drawings and welding book giving full information of the welds to be performed.
  - Pre-WPS (Preliminary -Welding Procedure Specification) according to chosen welding standard (\*\*)
  - Weld coupon and perform tests & inspections according to chosen standard (\*\*)
- (\*\*): HNB VVPSS Box compliant with Manufacturing code as table 1

[53\_IO\_NB\_VVPSSBT-R 073] The manufacturer shall issue a Distortion Management Plan (item 17 of table 5 to be included in the Manufacturing Design Report (item 34 of table 6).

[53\_IO\_NB\_VVPSSBT-R 074] The Distortion Management Plan shall detail :

- how the manufacturer Supplier plans to reduce the distortions during welding, possibly with the use of jigs or fixtures,
- if coupons and/or simulations are foreseen

**SUPPLY**

- how and when the distortions will be measured.

[53\_IO\_NB\_VVPSSBT-R 075] The NDE Procedure (item 19 of table 5) shall include:

- The Radiography Examination procedure(s)
- The Liquid Dye Penetrant Examination procedure(s)The Visual Examination procedure(s)
- The Alternative NDE procedure(s) if any

[53\_IO\_NB\_VVPSSBT-R 076] NDE operators ‘qualification (s) certificates shall be provided and kept up to date during the management of the Procurement.

[53\_IO\_NB\_VVPSSBT- INFO 90] The main phases of the overall procurement cycle are listed below:

1. Tendering for the manufacturing contract
2. Manufacturing Readiness Review (includes the preparatory work necessary to issue the documentation for the MRR).
3. Manufacturing
4. Factory Acceptance Test (FAT) (includes FAT test and delivery of the associated documentation)
5. Transportation, Delivery at ITER site,
6. Site Acceptance Test (SAT) and Final acceptance of the components at the IO site

[53\_IO\_NB\_VVPSSBT- INFO 91] The content and requirements of each phase are detailed in the following sections.

5.7.5 *Share of Responsibilities*

[53\_IO\_NB\_VVPSSBT- INFO 92] The sharing of responsibilities between the Parties is summarized in Table 6 and is further detailed in the following sections.

Re1 = Responsible for organizing,

Re2 = Responsible for performing and for the content,

A1 = Review & Comment

A2 = Acceptance

A3 = Approval

S = Providing technical support

\*: The support entails that the manufacturer provides constructive feedback and shares lessons learned while performing all required tests and during the factory assembly, which could assist IO in the VVPSSB Trolley and VVPSS Box installation at ITER.

Table 9 List of documentation to be provided during Technical review Milestone

Description of the Activity	IO	Manufacturer
Design of component		
The final design of the component, including 3D Models and 2D drawings	R	-
Technical specification	R	-

**SUPPLY**

Call for tender and contract award		
Market survey and preparation of call for tender, including contract documents	R	-
Technical evaluation of bidders and contract awards	R	-
Manufacture, Assembly, Factory Acceptance Test (FAT), and Delivery		
Manufacturing Design	A	R
Manufacturing drawings	A	R
Quality Plan (QP)	A	R
Manufacturing and Inspection Plan (MIP)	A	R
Manufacturing Readiness Review (MRR)	A	R
Materials and component procurement	A	R
Manufacturing and assembly	A	R
Factory Acceptance Testing, including manufacturing documentation	A	R
Delivery Readiness Review (DRR)	A	R
Packing and Delivery to the IO Site	A	R
As-built drawings and 3D models	A	R
Integration and Acceptance at the Site		
Incoming inspection at the IO site	A	R
Site Acceptance Test	R	S
Installation of the component at the IO site *	R	S
Commissioning of component *	R	S

5.7.6 Procurement follow-up

5.7.6.1 Notification Points, Authorizations-to-Proceed Points, Hold Points, Witness Points

[53\_IO\_NB\_VVPSSBT-R 077] The manufacturer shall ensure a close oversight of the production of its main Suppliers in accordance with an approved Manufacturing and Inspection Plan (MIP) [65].

[53\_IO\_NB\_VVPSSBT- INFO 93] This monitoring will include Provisional Notification Points, Authorization-To-Proceed Points, Hold Points and Witness Points at critical steps in the Suppliers’ plans. Final control points will be decided when the MIPs are submitted

[53\_IO\_NB\_VVPSSBT-R 078] The Control Points shall be integrated into the agreed schedule and MIPs, as defined in Section 8 of [2].

[53\_IO\_NB\_VVPSSBT- INFO 94] The control point definition has been copied from the Inspection Plan (IP) Template [65]:

- Hold Point (HP): Identifies an operation that must be signed off by an IO representative before work proceeds beyond this point.
- Authorization to Proceed Point (ATPP): Identifies an operation that must be signed off by the manufacturer representative before work proceeds beyond this point.

### SUPPLY

- Notification Point (NP): Identifies an operation that must be notified to an IO representative. This notification gives the IO representative the opportunity to arrange an inspection visit if deemed necessary therefore adequate notice must be given to permit arrangements for this visit. In the absence of the appointed representative and with IO documented agreement work can proceed.
- Witness (W): identifies an operation that must be witnessed.
- Review (R): identifies a document or report that must be reviewed.
- Where R/W is used for Radiography, this means that actual radiographs must be checked as well as the reports

[53\_IO\_NB\_VVPSSBT- INFO 95] A Notification Point (NP) (\*) The Notification will be sent by the Supplier at least 10 working days prior to the scheduled manufacturing step.

The manufacturer will inform the IO of the Suppliers' Notification within 4 working days and the manufacturer and the IO will decide whether or not they want to attend within the following 4 working days. A NP will not affect the production flow of the Supplier that shall continue the work even without a reply from the manufacturer and/or IO.

Authorization-To-Proceed Point (ATPP) (\*) The manufacturer will have 4 working days to review the Supplier's data and to notify the IO of its decision. The IO will have 3 working days to review the manufacturer decision. Beyond these 3 working days and if there is no IO reaction, the manufacturer will notify the Supplier of its decision. In case of authorization, the Supplier will proceed to the next task or to the next action on the specific deliverable. In case of rejection, the Supplier will develop with the manufacturer a recovery plan that will be submitted and reviewed by the IO within 5 working days of submission. In case of IO objection, the IO will detail its motives in writing and the manufacturer will have 5 working days to answer the IO objection and, whenever suitable, develop a recovery plan with the Supplier. An ATPP will only affect the specific task or the specific deliverable it is associated with and will not interfere with the execution of other tasks of the production or other deliverables of the same kind.

Hold Point (HP) (\*). The manufacturer will have a maximum of 5 working days to review the Suppliers data and to notify the IO of its decision and the IO will have a maximum of 5 working days to review the manufacturer assessment and to confirm or reject it. In case of clearance, the Supplier will resume its activity. In case of rejection, the Supplier will develop with the manufacturer a recovery plan that will be submitted and reviewed by the IO within 10 working days of submission. In case of IO objection, the IO will detail its reasons in writing and the manufacturer will have 10 working days to answer the IO objection and, whenever suitable, develop a recovery plan with the Supplier.

(\*): The time span defined for the different actions described above are not tagged as requirement and could be re-assessed case by case during the Kick-Off-Meeting and MRR regarding the complexity of the documents to review.

Witness Point (W) Adequate notice will be given to the IO, in order to allow the IO to participate to the operation.

[53\_IO\_NB\_VVPSSBT- INFO 96] IO will define the final control points when the manufacturing plan, MIPs and associated drawings are submitted.

[53\_IO\_NB\_VVPSSBT- INFO 97] The list of NPs, ATPPs, HPs and W to be implemented during the various phases of this procurement will be defined mutually between the IO and the supplier, as regards to project phasing.

**SUPPLY**

[53\_IO\_NB\_VVPSSBT- INFO 98] A preliminary list of Control Points is defined in Table 10 - Preliminary list of control points and associated documentation. Additional Control Points may be identified following review of the MIPs.

*Table 10 Preliminary List of control points and associated documentation*

Phase	Activities	IO	Comments
<b>Tendering for manufacturing</b>			
Offer reception	Technical offers	R	
<b>Phase 0: WP_PM0 – Project management and Quality</b>			
PM0-1 - Kick Off Meeting		HP	
PM0-2 - Approval of PQMP and schedule baseline		NP	
PM0-3 - Long Lead Time components identified		NP	
PM0-4 - Approval of baseline SCAR, Risk register, Top level Control plan		NP	
PM0-5 - Approval of the MRR Plan and of the qualification plan		HP	
PM0-6 - Approval of the plan for audits and inspections at the premises of the subcontractors		NP	
PM0-7 - All MRR reports approved		NP	
<b>Phase 1: WP_E1 – Engineering</b>			
All documentations defined in table 6	See table 6	TBD	TBD during the Kick of meeting of the manufacturing contract according to list of documents to be provided at the MRR.
<b>Phase 2 : WP_Q2 – Qualifications and factory preparation</b>			
Welding/machining inspection and test report		NP	
<b>Phase 3: WP_P3 - Procurement</b>			
Purchase order for material procurement		NP	
<b>Phase 4: WP_M4 - Manufacturing and Tests during manufacturing</b>			
Weld inspection (visual, surface NDE, volumetric NDE)	Weld inspection	NP	
Documentation related to each task	Documents related to each task	R	The IO approval of the documentation related to safety clear the R. The IO acceptance of the documentation related to non-safety clear the R
<b>Phase 5: WP_T5 – Factory Acceptance Testing</b>			
Dimensional and visual inspection	Metrology and visual inspection	NP	
	Metrology and Inspection report	R	The IO approval of the documentation related to safety clear the R. The IO acceptance of the documentation related to non-safety clear the R
Electrical test of thermocouples and heating elements	Baking Electrical test	NP	
	Baking Electrical test report	R	The IO acceptance of the documentation related to non-safety clear the R
Test of baking function	Baking function test	HP	
	Baking capability test report	R	The IO acceptance of the documentation related to non-safety clear the R
Cold Vacuum Leak Test	Cold Vacuum Leak Test	HP	
	Cold Vacuum Leak Test report	R	The IO approval of the documentation related to safety clear the R.

**SUPPLY**

			The IO acceptance of the documentation related to non-safety clear the R
Hot Vacuum Leak Test	Hot Vacuum Leak Test	HP	The IO approval of the documentation related to safety clear the HP.
	Hot Vacuum Leak Test report	R	The IO acceptance of the documentation related to non-safety clear the R
Test of the Helicoflex metallic seal Only if free issued (Helicoflex seals) items are provided on time	Helicoflex metallic seal test	HP	
	Helicoflex metallic seal test report	R	The IO approval of the documentation related to safety clear the R. The IO acceptance of the documentation related to non-safety clear the R
Outgassing rate acceptance tests	Outgassing rate acceptance test	HP	
	Outgassing rate acceptance test report	R	The IO approval of the documentation related to safety clear the R. The IO acceptance of the documentation related to non-safety clear the R
Test of Assembly VVPSS Box Trolley	Trolley function test	HP	
	Test report	R	The IO acceptance of the documentation related to non-safety clear the R
End of manufacturing documentation	End of manufacturing documentation	HP	The IO approval of the documentation related to safety clear the HP. The IO acceptance of the documentation related to non-safety clear the HP
<b>WP_D6 – Packing, Transport and Delivery</b>			
Final cleaning (see section 9.4)	Final cleaning	ATPP	
	Final cleaning report	R	The IO approval of the documentation related to safety clear the R. The IO acceptance of the documentation related to non-safety clear the R
Packing	Packing, shipping, handling procedure	HP	The IO approval of the documentation related to safety clear the HP. The IO acceptance of the documentation related to non-safety clear the HP
	Packing inspection	NP	Done during packing, before shipment
Delivery	Delivery report review	HP	The IO approval of the documentation related to safety clear the HP. The IO acceptance of the documentation related to non-safety clear the HP. The IO acceptance of the documentation clears the HP, and is necessary to start shipment
	Inspection after shipment	NP	
	Inspection report review and Final Acceptance Certificate	R	The approval of the Final Acceptance Certificate closes the PA
<b>WP_S7 - IO Site Acceptance</b>			
	Site Acceptance, as mentioned in section 9.3.4	HP	
	SAT report	HP	

**5.7.6.2 Data Management**

[53\_IO\_NB\_VVPSSBT-R 079] Exchange of documentation between the Supplier and the IO shall comply with the reference 13 of [2] (IO / In-Cash Contractor Documentation Exchange and Storage Working Instruction)

### SUPPLY

- [53\_IO\_NB\_VVPSSBT-R 080] These engineering data shall be organized according to the “ITER Document Breakdown Structure Overview” [7] and [9].
- [53\_IO\_NB\_VVPSSBT-R 081] The electronic documentation generated by the Supplier that cannot be entered into the ITER IDM shall be handled electronically and entered into an IO existing database similar to the ITER IDM, if the type of Items requires so (e.g. NCR database, SMDD, etc.)
- [53\_IO\_NB\_VVPSSBT-R 082] The documentation folder structure of the IO existing database shall be defined by the manufacturer in agreement with IO.
- [53\_IO\_NB\_VVPSSBT-R 083] Data flow from the Supplier to IO, when applicable: Relevant data shall be made available by the supplier through the database each time a control point is requested, or a deviation request is issued by the Supplier [34].
- [53\_IO\_NB\_VVPSSBT-R 084] The Supplier shall perform the following documentation services:
- provide the documents and data defined in the This TS
  - upload 2D drawings in SMDD in agreement with IO.
  - Integrate IO manufacturing database (MDB) in their operations.
  - Integrate IO NCR Database for non-conformance reporting/management (*section 8 of [2]*)
  - Provide analysis models (if some have been performed by the Supplier) to IO (*ref 23 of [2]*)
  - Exchange of documentation between the Supplier and IO conforming the requirements as defined in (section 6 of [2])
  - Define the document folder structure of the databases in agreement with IO (*[7] & [9]*)
  - Use and work in accordance with the databases required to store information related to the Contract (such as. Manufacturing database, SMDD and NCR database;
  - manage CAD data files through specialized CAD software (CATIA v5) and in accordance to other requirements which are specified in reference 7 of [2];
  - Upkeep of a data record of contract documents / data in agreement with IO.

#### 5.7.6.3 IO Reviews

[53\_IO\_NB\_VVPSSBT- INFO 99] The Manufacturing Readiness Review can be performed in accordance with the IO working instruction for Manufacturing Readiness Review [62].

[53\_IO\_NB\_VVPSSBT- INFO 100] The Working Instruction for Manufacturing Readiness Review [62] provides requirements and methods for the implementation of MRRs of the ITER components, system or subsystem and it is applicable to IO, the Suppliers and subcontractors who perform manufacturing activities.

[53\_IO\_NB\_VVPSSBT-R 085] The successful MRR shall close the phase 2 (Table 5,6 & 7).

## SUPPLY

[53\_IO\_NB\_VVPSSBT- INFO 101] In addition, to the Manufacturing Readiness Review, during the manufacturing phase, the IO and the manufacturer can organize Status Reviews (SRs) and Quality Control Reviews (QCRs) by mutual agreement.

[53\_IO\_NB\_VVPSSBT- INFO 102] These may be focused on particular areas of production and will be organized by IO as required by the progress and performance. The definition, occurrence and maximum duration of these possible SRs and QCRs will be defined in the Technical Specification for the tendering for fabrication (Phase 1 – table 6 and discussed at the MRR meeting.

## 6 Technical Requirements

[53\_IO\_NB\_VVPSSBT- INFO 103] This document describes the technical requirements related to the procurement of the **HNB VVPSS Box Items** for the Heating Neutral Beam 1 & 2.

### 6.1 Nuclear Safety Information & requirements

[53\_IO\_NB\_VVPSSBT-R 086] **The scope under this contract covers for PIC and PIA, [2] GM3S section 5.3 shall apply.**

#### 6.1.1 Nuclear Safety Information

[53\_IO\_NB\_VVPSSBT- INFO 104] The VVPSS Box as a PIC will ensure the following nuclear safety function:

- Confinement : The VVPSS Box is part of the First confinement barrier
- Minimization of radiological exposure: the used Material that will be activated will have a low concentration of Cobalt, Niobium and Tantalum (requirements are in section 6.4.2 Material).

[53\_IO\_NB\_VVPSSBT- INFO 105] For the requirement here above, IO enlightens that the manufacturer will refer to the document ref 6 of [2]: Provisions for Implementation of the Generic Safety Requirements by the External Interveners which is IO's propagation in their supply chain of INB Order requirements

[53\_IO\_NB\_VVPSSBT- INFO 106] In this TS, the defined requirements are identified in red.

- These defined requirements have been identified according to the document [58].
- The PIAs for the VVPSS Box are defined in the document [16].

[53\_IO\_NB\_VVPSSBT- INFO 107] Regarding the Nuclear safety function “confinement”, the main PIAs for the VVPSS Box are the following:

- All Analysis (out of the scope of this TS) based on the Loads Specification [4] ensuring the integrity of the confinement of the VVPSS Box
- All Activities linked to the Welding data Book and the associated controls.

Regarding the Nuclear safety function << minimization of radiological exposure>>, the main PIAs for the VVPSS Box are the following:

- The chemical composition analysis of the material
- Material certificate delivery

### SUPPLY

[53\_IO\_NB\_VVPSSBT- INFO 108] Other activities related to the VVPSS Box manufacturing and delivery, like for example; the transportation to IO site, are also classified as PIAs. The list of the PIAs will be further developed by the supplier, where needed (during MRR and all along the procurement and manufacturing process), in accordance with the PIA guidelines

[53\_IO\_NB\_VVPSSBT- INFO 109] It is important to remind to the following document:

- Provisions for Implementation of the Generic Safety Requirements by the External Interveners - ref 6 of [2]
- [62] Requirements Propagation Matrix (RPM) from Project Requirements (PR) to System Requirements Document (SRD) 53-01 in the specific context of Safety Items
- Overall Surveillance Plan of External Interveners Chain for Protection Important Components, Structures and Systems and Protection Important Activities – [11]
- Guideline for Identification of the Protection Important Activities (PIA) –[14]

[53\_IO\_NB\_VVPSSBT- INFO 110] The VVPSS Box, the Blank Fange, the Anchor system and the VVPSSB Trolley are NOT classified PED/ESPN component.

#### 6.1.2 Nuclear Safety requirements

[53\_IO\_NB\_VVPSSBT-R 087] The supplier shall explain in its Quality Plan , the dispositions taken to implement the nuclear safety requirements requested in ITER\_D\_SBSTBM - MQP L3 Provisions for Implementation of the Generic Safety Requirements by the External Actors/Interveners [ref.6 of [2]]

[53\_IO\_NB\_VVPSSBT-R 088] All along the scope of work for this TS, a surveillance (see also [65]) shall be performed on the PIAs (manufacturing activities) identified in [16].

[53\_IO\_NB\_VVPSSBT-R 089] In line with the implementation plan, IO may conduct audit of the manufacturer and its supply chain. Any related document and site shall be accessible

### 6.2 General requirements

[53\_IO\_NB\_VVPSSBT- INFO 111] The functional requirements to be met by the NB System are defined in the SRD document [51].

[53\_IO\_NB\_VVPSSBT- INFO 112] For the HNB VVPSS Box, the SRD is substituted by a series of Applicable Documents (section 11) which contain detailed requirements to be met during the execution of the procurement.

### 6.3 Functional requirements

[53\_IO\_NB\_VVPSSBT- INFO 113] It is understood that the respect of the Functional Requirements of the HNB VVPSS Box Items consists in the propagation of the Design requirements to the Manufacturing requirements.

### SUPPLY

[53\_IO\_NB\_VVPSSBT- INFO 114] IO has designed the HNB VVPSS Box Items up to the Final Design level in compliance with the IO design requirements. The Final Design Review of the HNB VVPSS Box has been carried out according to the Design Review Procedure

[53\_IO\_NB\_VVPSSBT-R 090] The supplier shall ensure that all the functional requirements, respected at Design phase by IO, are well propagated during the Manufacturing phase.

[53\_IO\_NB\_VVPSSBT-R 091] The supplier shall ensure that all the technical requirements (from this TS including those of the Application Documents) are well propagated during the Manufacturing phase.

[53\_IO\_NB\_VVPSSBT-R 092] The supplier shall take into consideration the welds study [60].

[53\_IO\_NB\_VVPSSBT-R 093] If the Supplier wants to do differently it shall demonstrate that the welds (different of [84]) are compliant (design and fabrication and NDE control) with the code.

[53\_IO\_NB\_VVPSSBT-R 094] The finishing of the vacuum exposed surfaces as reported on the Build-To-Print drawings listed in the Bills of Material [17] & [18] shall be respected.

### 6.4 Material

[53\_IO\_NB\_VVPSSBT- INFO 115] All existing requirements for materials and impurities in steels and alloys in ITER are defined in the document Chemical composition and impurity requirements for materials [6].

[53\_IO\_NB\_VVPSSBT-R 095] Except when specified differently in this TS (that includes the BoM [17][18]), the base materials of the HNB VVPSS Box shall comply with the requirements defined in section 6.4 and table 1 for PBS-53 of [6].

[53\_IO\_NB\_VVPSSBT-R 096] In case of discrepancy, on the impurity values between the AD [6] and the BoM [17] & [18], it shall be taken the values of BoM [17] & [18]

[53\_IO\_NB\_VVPSSBT-R 097] In case of discrepancy, on the material designation, between the drawings and the BOM [17] & [18], it shall be taken the ones of the BOM [17] & [18].

[53\_IO\_NB\_VVPSSBT-R 098] Pipes and tubes shall be of seamless construction.

[53\_IO\_NB\_VVPSSBT-R 099] Any deviation to the material composition given below and to the Bills of Material [17] & [18] shall be managed through a deviation following the procedure [34].

[53\_IO\_NB\_VVPSSBT-R 100] The use of a different or additional material not defined in the Bills of Material [17] & [18] shall be approved by the IO.

## SUPPLY

[53\_IO\_NB\_VVPSSBT- INFO 116] During the design phase, as mentioned in chapter 4.5 of ITER Tritium Handbook [8], IO has avoided the use of Halogenated materials, sulphur and phosphorus for the HNB VVPSS Box that is Tritium Classified. Indeed, these materials lead to potential for oxidation catalyst poisoning and to metallic corrosion due to acid formation.

[53\_IO\_NB\_VVPSSBT-R 101] As mentioned in chapter 3.2 of ITER Tritium Handbook [8], requests for deviations from, and non-conformance with, the requirements of the ITER Tritium Handbook shall be made to the ITER Organisation in writing following the procedures detailed in ITER Quality Assurance Program (QAP) [19]. The IO approval will be done through the joint approval of an Interface Control Document pertaining to tritium (ITER Tritium RO PBS 3.2).

[53\_IO\_NB\_VVPSSBT- INFO 117] All the materials, for use in vacuum, have been selected and defined in the Bill of Material by IO, respecting the requirements from chapter 5.1 and 5.2 of the Vacuum Handbook [5].

[53\_IO\_NB\_VVPSSBT-R 102] As a tritium confinement boundary the plates of the HNB VVPSS Box shall respect the following requirement from chapter 4.6 – Plate material of ITER Tritium Handbook [8]:

For Tritium Classifications 1A, 2A and 2B materials, hot or cold rolled plate material shall be used with the direction of rolling parallel to the surface of the confinement boundary to the maximum extent practicable. Where transverse sections have to form part of the confinement boundary, a low inclusion rate material shall be used which meets the inclusion limits as specified in the section 5.3.1 of the ITER Vacuum Handbook and shall be proven by helium leak testing (section 7.1.3.6).

[53\_IO\_NB\_VVPSSBT-R 103] As defined in 5.3.1 of the Vacuum Handbook [5], all VQC 1A components of the VVPSSB items which are machined from steel, austenitic steel or superalloys and which are of final thickness less than 5 mm shall be manufactured from cross forged material which is Electro slag Remelted (ESR) or Vacuum Arc Remelted (VAR) as requested in section 5.3.1/5.3.3 of the ITER Vacuum Handbook.

[53\_IO\_NB\_VVPSSBT-R 104] For final thickness < 5mm of VQC 1A, the rate of inclusions (as per section 5-3.1 of Vacuum Handbook [5]) in the steel shall be checked in accordance with ASTM E-45 Method D (or equivalent) to be within the following inclusion limits:

- Inclusion Type A  $\leq$  1.0.
- Inclusion Type B  $\leq$  1.0.
- Inclusion Type C  $\leq$  1.0.
- Inclusion Type D  $\leq$  1.5.

[53\_IO\_NB\_VVPSSBT- INFO 118] Recommended by CERN experts, based on their experience: As during welding, inclusions can be segregated and form crack initiation. it could be important for structural integrity that the raw material, for the parts that need a weld, is procured with a low rate of inclusion regardless thickness.

## SUPPLY

[53\_IO\_NB\_VVPSSBT-R 105] As per section 5-3.2 of Vacuum Handbook [5], VQC 1A components which are machined and are of final thickness between 5 mm and 25 mm shall be manufactured from steel that has been cross-forged (upset forged).

[53\_IO\_NB\_VVPSSBT-R 106] For VQC 1, 2A & 3, metallic castings shall not be used (as per section 5-6 of Vacuum Handbook [5])

[53\_IO\_NB\_VVPSSBT-R 107] As per section 5-7 of Vacuum Handbook [5], for VQC1A components which have been assigned Remote Handling Class 3 (see table 2), hot or cold rolled plate produced with conventional smelting and refining processes such as Argon-Oxygen Decarburization (AOD), Vacuum Arc decarburization (VOD) shall not be used where the transverse cross section across the vacuum boundary (wall thickness) is less than 25mm.

[53\_IO\_NB\_VVPSSBT-R 108] As per section 5-7 of Vacuum Handbook [5], where for VQC1A components, hot or cold rolled plate material is used with the transverse cross section crossing the vacuum boundary (for wall thickness less than 25 mm), ESR or VAR low inclusion rate material shall be used which meets the inclusion limits as specified in section 5.3.1 of the [5].

[53\_IO\_NB\_VVPSSBT- INFO 119] To be noted that the following components are not VQC1A:

- The VVPSSB Trolley
- The Anchor system
- The SVS pipes

[53\_IO\_NB\_VVPSSBT-R 109] The Purchase Order Specification (or Product Procurement Specification) for based material of sub-assemblies for VVPSS BOX Items having to be procured with the RM (see column "Applicable RPS (Reference Procurement Specification) for material" of the BOMs [17] & [18]), shall be compliant with RM 011-0 of the code [1]

[53\_IO\_NB\_VVPSSBT-R 110] The Purchase Order Specification (or Product Procurement Specification) for based material of sub-assemblies, for VVPSS BOX Items shall be provided to IO for Acceptance.

[53\_IO\_NB\_VVPSSBT-R 111] All material for the VVPSS BOX Items shall be free from surface cracks and fissures, forge and other tool marks, burns, delamination and other defects according to the criteria defined in the RCC-MRX [1].

[53\_IO\_NB\_VVPSSBT- INFO 120] Particular care will be given to materials to be used as vacuum boundaries, since such defects would make them incompatible with a high vacuum environment.

[53\_IO\_NB\_VVPSSBT-R 112] For each ingot casting, the manufacturer of the raw material shall produce a raw material certificate in compliance with EN 10204 chapter 3.1.

### SUPPLY

- [53\_IO\_NB\_VVPSSBT-R 113] Each certificate shall have the approval of the IO before the start of the manufacture.
- [53\_IO\_NB\_VVPSSBT-R 114] For VVPSS BOX Items, the material shall follow the RM or the standard as specified in the column “Applicable RPS (Reference Procurement Specification) for material” the Bill Of Material [17] & [18].
- [53\_IO\_NB\_VVPSSBT-R 115] For the material of the VVPSS BOX Items, having to be procured with the RM (see column “Applicable RPS (Reference Procurement Specification) for material” of the BOM [17] & [18]), the inspection documents established as per NF EN 10204 type 3.1 shall include the conformity declaration – See RM 0116 of RCC-MR Code [1].
- [53\_IO\_NB\_VVPSSBT-R 116] Certification shall be in accordance with EN 10204 - See chapter 4.5 of ITER Tritium Handbook [8].
- [53\_IO\_NB\_VVPSSBT-R 117] All the data relevant to the certification EN 10204 shall be recorded in compliance with EN10168
- [53\_IO\_NB\_VVPSSBT-R 118] For VVPSS BOX Items, the material, having to be procured with the RM (see column “Applicable RPS (Reference Procurement Specification) for material” of the BOM [17]), shall be qualified according to the Section 2 – Material of RCC-MRX [1] which lists all the tests and acceptance criteria to be met.
- [53\_IO\_NB\_VVPSSBT-R 119] For material of VVPSS BOX Items parts, having to be procured with the RM (see column “Applicable RPS (Reference Procurement Specification) for material” of the BOM [17]), the supplier shall follow test methods that are defined in Tome III: Control methods of RCC-MRX [1].
- [53\_IO\_NB\_VVPSSBT-R 120] For VVPSS BOX Items, the Stainless Steel parts shall be the X2CrNiMo17-12-2 Nitrogen controlled unless written differently in the Bill of Material [17] & [18].
- [53\_IO\_NB\_VVPSSBT- INFO 121] For VVPSS BOX Items, the X2CrNiMo17-12-2 Nitrogen controlled material having to be procured with the RM (see column “Applicable RPS (Reference Procurement Specification) for material” of the BOM [17] & [18]), is described in the RCC-MRX Code [1] Section A3.1S.
- [53\_IO\_NB\_VVPSSBT- INFO 122] For material of the VVPSS BOX Items , having to be procured with the RM (see column “Applicable RPS (Reference Procurement Specification) for material” of the BOM [17] & [18]), the specification of X2CrNiMo17-12-2 (N) is based on the product procurement specification:
- RM 333-0 for plates,  
RM 332-0 for rolled or forged bars in RCC-MRX [1]
- [53\_IO\_NB\_VVPSSBT- INFO 123] The plates and forgings are considered for equipment Class N2rx (in accordance with RCC-MRX classification).

**SUPPLY**

[53\_IO\_NB\_VVPSSBT-R 121] The chemical composition determined by ladle and product analyses of X2CrNiMo17-12-2 shall comply with the requirements given in Table 8 below extracted from [63] and [6] unless written differently in the Bill of Material [17] & [18] for what concerns the Additional ITER specific requirements (Co, Nb Ta, Ti):

Table 8: Chemical composition of X2CrNiMo17-12-2 controlled nitrogen for the VVPSS Box Items [17] & [18]

Chemical composition, X2CrNiMo17-12-2 controlled nitrogen	Content in Wt. %
<i>Elements</i>	<i>Range or Max</i>
Fe	balance
C	0.030
Mn	1.60 - 2.00
Si	0.50
P	0.030
S	0.015
Cr	17.00 - 18.00
Ni	12.00 – 12.50
Mo	2.30 – 2.70
N	0.060-0.080
Cu	1.00
B	0.0020
<b>Additional ITER specific requirements [6] and [93]:</b>	
Co	0.05
Nb	0.01
Ta	0.01
Ti	0.10

(\*) As written in Section 4.5 of Tritium Handbook: “Halogenated materials, sulphur and phosphorus, and processes involving the use of these materials, shall be avoided when possible for all components having a Tritium Classification. These materials lead to potential for oxidation catalyst poisoning and to metallic corrosion due to acid formation. If use of these materials cannot be avoided, the content of these materials in Tritium Classification 1 and 2 systems shall be limited to 0.025% of each”. Nevertheless, requirement related to sulphur and phosphorus shall be considered for the case where chemically active sulphur and phosphorus is released in the process streams of the systems such as VV and fuel cycle. This is not the case for metallic materials of construction of the VVPSS Box Items.

### SUPPLY

[53\_IO\_NB\_VVPSSBT-R 122] All material for the parts of the VVPSS Box Items shall be free from surface cracks and fissures, forge and other tool marks, burns, delamination and other defects according to the criteria defined in the European standard indicated in the BOM [17][18].

[53\_IO\_NB\_VVPSSBT-R 123] The material for the VVPSS Box Items shall be supplied with a 3.1 certificate in accordance with EN 10204.

[53\_IO\_NB\_VVPSSBT- INFO 124] The materials of bolts have been defined according to the definition of the Final design Analysis report [67].

[53\_IO\_NB\_VVPSSBT- INFO 125] Depending on the use and the location into the VVPSS Box Items and Trolley, the Bolts (nuts, washers, etc.) have different material grade requirements that are defined in the Bill of Material [17] & [18].

[53\_IO\_NB\_VVPSSBT-R 124] The bolts, nuts, and washers, shall be procured in compliance with the grade and Code or Standard written in the Bill of Material [17] & [18].

[53\_IO\_NB\_VVPSSBT- INFO 126] There are different bolts integrated in the VVPSS Box item:

- Non-preloaded assembly bolts mounted
- Preloaded assembly bolts maintaining leak tightness (interface VVPSS Box and Blanking Flange).

[53\_IO\_NB\_VVPSSBT- INFO 127] The material of bolts, washers and inserts defined at FDR in the analysis report [104] are

- 660 grade steel according to A3.1B (Section1-Subsection Z-Appendix A3of RCC-MR 2007 [1])
- 42CrMo4 according to A3.11B (Section1-Subsection Z-Appendix A3of RCC-MR 2007 [1])
- NiCr19Fe19Nb5Mo3 according to A.B01/S10 of SDC-IC- Appendix A[69]

[53\_IO\_NB\_VVPSSBT-R 125] The NiCr19Fe19Nb5Mo3 (similar to Inconel 718) bolts shall be procured through a Purchase Order compliant with specification [20].

[53\_IO\_NB\_VVPSSBT- INFO 128] The metallic seals implemented are defined as standard metallic seals.

[53\_IO\_NB\_VVPSSBT-R 126] All off the shelf parts, such as gaskets, standard Helicoflex® spring energized seals, etc. shall be procured as defined in the Bill of Material [17] & [18].

[53\_IO\_NB\_VVPSSBT- INFO 129] The materials of the Helicoflex® spring energized seal are:

- Spring is made of Inconel 718 alloy.
- Inner Jacket is made of 304L stainless steel.

## SUPPLY

- Sealing lining is made of pure silver.

### 6.5 Manufacturing requirements

[53\_IO\_NB\_VVPSSBT-R 127] The manufacturing of the VVPSS BOX Items shall follow the rules of the Tome 4 & 5 from RCC-MRX [1].

[53\_IO\_NB\_VVPSSBT-R 128] Part of the manufacturing, in particular the final assembly, shall be performed in a suitably clean area.

[53\_IO\_NB\_VVPSSBT-R 129] The tolerances to be fulfilled by the components and subassemblies shall be as specified on the Build-To-Print drawings listed in the Bills of Material [17] and [18].

[53\_IO\_NB\_VVPSSBT-R 130] Based on the Build-To-Print Drawings, the manufacturer shall develop the detailed manufacturing drawings to be provided at MRR, showing also the functional tolerances (geometrical and form) and surfaces finishing.

[53\_IO\_NB\_VVPSSBT-R 131] The manufacturing drawings shall be accepted by IO before the start of the manufacture.

[53\_IO\_NB\_VVPSSBT-R 132] The manufacturing shall develop the manufacturing and assembly process to guarantee the fulfilment of the required dimensional and geometrical (form and positional) tolerances as well as the specified surface finish.

[53\_IO\_NB\_VVPSSBT- INFO 130] The Build to Print drawings indicate the functional tolerances that are necessary for the operation and the use of the VVPSS Box Items at ITER.

[53\_IO\_NB\_VVPSSBT- INFO 131] General tolerances, and in particular profile tolerances are indicated on the build to print drawings and are applicable to the components.

[53\_IO\_NB\_VVPSSBT- INFO 132] It is in the Supplier's responsibility to define all the manufacturing tolerances that are not specified on Build to Print drawings and that will ensure assembly of the parts as well as compliance with the geometrical requirements.

[53\_IO\_NB\_VVPSSBT-R 133] Any dimension not specifically indicated on the Build to print drawing shall be extracted from the 3D model by the supplier.

[53\_IO\_NB\_VVPSSBT-R 134] Based on the 3D model and on the Build-to-Print drawings, the supplier shall determine any tolerance not specifically requested on the build to print drawings and that is necessary to ensure:

- Assembly of the parts together,
- Compliance with all the tolerances specified on the build to print drawings, and in particular the tolerances specified on the assembly drawings.

[53\_IO\_NB\_VVPSSBT-R 135] Any tolerance necessary to the parts shall be specified by the supplier on the manufacturing drawings supplied at MRR.

[53\_IO\_NB\_VVPSSBT-R 136] The supplier shall demonstrate at the MRR how the tolerances defined on the manufacturing drawings will ensure the assembly of the parts.

## SUPPLY

- [53\_IO\_NB\_VVPSSBT-R 137] The supplier shall demonstrate at the MRR how the tolerances defined on the manufacturing drawings will ensure compliance with the tolerances specified on the IO Build to Print drawings.
- [53\_IO\_NB\_VVPSSBT-R 138] The manufacturer shall foresee any additional equipment necessary to test, handle and support safely the HNB VVPSS Box Items during the manufacture.
- [53\_IO\_NB\_VVPSSBT-R 139] Any not foreseen operations in the Manufacturing Inspection Plan (MIP) provided during the MRR (see section 4.3.2) as, heat treatment for stress relieving, restoration of material properties, outgassing or any other purpose on assemblies or components shall be marked by the Supplier in an update of the Manufacturing Inspection Plan document.
- [53\_IO\_NB\_VVPSSBT-R 140] The update of the Manufacturing Inspection Plan document shall be submitted to IO for acceptance.

### 6.6 Requirements for the manufacturing of vacuum components

- [53\_IO\_NB\_VVPSSBT-R 141] The vacuum-facing surfaces of this component shall have a maximum average surface roughness of 6.3µm, measured by electric stylus, in accordance with ISO 4297:2000, as listed in Table 8-1 of the ITER Vacuum Handbook [5].
- [53\_IO\_NB\_VVPSSBT-R 142] The use of files, harsh abrasives, sand, shot or dry bead blasting, polishing pastes and the like is prohibited under normal circumstances and shall not be used without prior agreement with the IO vacuum RO (requirement from ITER Vacuum Handbook [5]).
- [53\_IO\_NB\_VVPSSBT-R 143] Cutting fluids for use on VQC 1 and 3 components shall be water soluble, non-halogenated and phosphorus and sulphur Free. The maximum allowable content of halogens, phosphorus, and sulphur is 200 ppm each (Chapter 6 of the ITER Vacuum Handbook [5]).
- [53\_IO\_NB\_VVPSSBT-R 144] A list of the Accepted fluids (cutting, cleaning, dye penetrant) that can be used for the VVPSS Box manufacturing is given in [73]. If another fluid (not in the list) is required, using the procedure [71], "Request for acceptance of fluid" shall be raised to IO.
- [53\_IO\_NB\_VVPSSBT-R 145] If grinding is essential on VQC 1 systems, the grinding wheel shall be free of organic components.
- [53\_IO\_NB\_VVPSSBT-R 146] If grinding is essential on VQC 1 systems, the grinding wheel shall have been manufactured in an oil-free, clean environment.
- [53\_IO\_NB\_VVPSSBT-R 147] The material and manufacturing process of the grinding wheel shall be accepted by the ITER Vacuum RO before use.

## SUPPLY

[53\_IO\_NB\_VVPSSBT-R 148] Appendix 4 [73] of the ITER Vacuum Handbook lists the manufacturing consumables (grinding wheels, tapes, fluids...) already accepted for the manufacturing of ITER components as well as the precautions related to their use. If another consumable (not in the list) is required, a "Request for acceptance" shall be raised to IO.

## 6.7 Welding

[53\_IO\_NB\_VVPSSBT-R 149] The welding requirements for ITER are documented in the Vacuum Handbook Attachment 1 Welding [10]. These requirements shall apply to Vacuum Class 1 & 3 parts of the HNB VVPSS Box (see table 1).

[53\_IO\_NB\_VVPSSBT- INFO 133] The Vacuum Handbook Attachment 1 imposes more stringent requirements than International Standards:

- The qualification ranges for weld procedures are more limited than ASME or EN
- The acceptance criteria for weld defects are stricter than ASME, EN and RCC-MR

[53\_IO\_NB\_VVPSSBT-R 150] Suitable devices (jigs and fixtures) shall be used to prevent welding distortions.

[53\_IO\_NB\_VVPSSBT-R 151] If jigs and fixtures are used to limit welding distortions, design and manufacturing drawings (including their material) developed by the manufacturer shall be submitted to IO for acceptance.

[53\_IO\_NB\_VVPSSBT-R 152] Welding processes shall be developed in order to minimize distortions, leading to the fulfilment of all the tolerances requirements.

[53\_IO\_NB\_VVPSSBT-R 153] Welded attachments of jigs shall not cross or cover pressure retaining welds.

[53\_IO\_NB\_VVPSSBT-R 154] Welded attachments of jigs shall be compatible with the performance of required NDE.

### 6.7.1 Welder and Operator Qualification

[53\_IO\_NB\_VVPSSBT-R 155] For the VVPSS BOX Items and the VVPSSB Trolley the qualification tests for welders and operators shall be carried out in compliance with RS 4000 – Section IV [1].

[53\_IO\_NB\_VVPSSBT-R 156] For the VVPSS BOX Items and VVPSSB Trolley, as per RS 4210 [1], welders qualification shall be in accordance with EN ISO 9606-1 for welding steel and in standard EN ISO 9606-4 for welding nickel –base alloys.

[53\_IO\_NB\_VVPSSBT-R 157] For welding operators using fully mechanized, robotized or automatic welding procedures EN ISO 14732 shall be used.

## SUPPLY

[53\_IO\_NB\_VVPSSBT-R 158] Each performance qualification welder testing shall be done under full supervise control and approved by a third party (or inspection body).

### 6.7.2 *Welding Procedure Qualification Record*

[53\_IO\_NB\_VVPSSBT- INFO 134] A Welding Procedure Specification (WPS) is the formal written document describing welding procedures, which provides direction to the welder or welding operators for making sound and quality production welds as per the code or standard requirements (see table 1).

[53\_IO\_NB\_VVPSSBT- INFO 135] A WPS is supported by a Welding Procedure Qualification Record (WPQR). A WPQR is a record of a test weld performed and tested to ensure that the procedure will produce a good weld. Individual welders are certified with a qualification test documented in a Welder Qualification Test Record (WQTR) that shows they have the understanding and demonstrated ability to work within the specified WPS.

[53\_IO\_NB\_VVPSSBT-R 159] All welding data and results from the required non-destructive and destructive testing shall be documented using a Procedure Qualification Record (PQR) endorsed by the witnessing Independent Inspection Authority (It can also be called Welding Procedure Approval Record (WPAR)).

[53\_IO\_NB\_VVPSSBT- INFO 136] An existing Welding Procedure Qualification Record (WPQR) is acceptable if the following conditions are met:

- The test must have been performed in the same environment as proposed for production, using the same welding technique, process, joint configuration and welding equipment (for mechanised welds)
- The allowable ranges are the same with regard to essential variables.
- The related Preliminary Welding Procedure Specification (PWPS) has been issued in accordance with ISO 15614
- The welding of test coupons and their tests must have been witnessed by an ITER recognised Independent Inspection Authority following ISO 17020.
- Regarding components to be manufactured with RCC-MR code, the witnessing Independent Inspection Authority is defined at the Register Third Party Inspector Organization (RTPIO) according to the RCC-MR.

### 6.7.3 *Welding Procedure requirements*

[53\_IO\_NB\_VVPSSBT-R 160] The welding process and weld preparation shall minimize shape defects in order to meet the tolerance requirements.

[53\_IO\_NB\_VVPSSBT-R 161] All welds shall be required to have a smooth finish which is compatible with applicable NDE techniques.

## SUPPLY

[53\_IO\_NB\_VVPSSBT- INFO 137] Manual and automatic arc and advanced welding processes can be utilized for the HNB VVPSS Box .

[53\_IO\_NB\_VVPSSBT-R 162] The VVPSS BOX Items shall comply with the requirements from RCC-MRX [1] section 1 (Sub-section C – RC 4000), section 3- Examinations method and section 4- Welding . Some of these requirements are detailed in the sections below.

### 6.7.4 Welding Procedure Qualification (WPQ)

[53\_IO\_NB\_VVPSSBT-R 163] The WPQ is the supplier's responsibility. Adequacy and validity shall be checked with IO before start of production welds.

[53\_IO\_NB\_VVPSSBT-R 164] The WPQ shall be valid for an unlimited time on condition that it is not invalidated (by agreement between the IO and the supplier by the appearance of repeated welding defects during manufacturing or in welding test coupons production.

[53\_IO\_NB\_VVPSSBT-R 165] The WPQ of the VVPSS BOX Items shall be conducted following RS 3000 Tome 4 of RCC-MRX [1].

[53\_IO\_NB\_VVPSSBT-R 166] The material weldability of VVPSS BOX Items shall conform to RS 1300 Tome 4 of RCC-MRX [1].

### 6.7.5 Acceptance of Filler material

[53\_IO\_NB\_VVPSSBT- INFO 138] Strength requirements for filler material are taken from filler material data sheets and are at least equal to the strength of the base material.

[53\_IO\_NB\_VVPSSBT-R 167] Adjustment of the filler material chemical composition on maximum Cobalt content may be needed if it cannot be compliant to requirements defined in section 7.2.2 of [6]. This possible adjustment shall be agreed with IO

[53\_IO\_NB\_VVPSSBT- INFO 139] The level of Cobalt for filler material is specified in 'Chemical composition and impurity requirements for materials' [6]. The impurities level for the NB System is taken Similar to PBS 15-VV and PBS 16-Blanket and 17-Divertor.

[53\_IO\_NB\_VVPSSBT-R 168] The level of cobalt shall be maximum 0.2% for filler material, as defined in section 7.2.2 of [6].

[53\_IO\_NB\_VVPSSBT-R 169] The qualification of the filler materials shall be done under the supervision of IO.

**SUPPLY**

[53\_IO\_NB\_VVPSSBT-R 170] The qualification reports of the filler materials shall be submitted to IO for approval.

[53\_IO\_NB\_VVPSSBT-R 171] Filler material certificate shall be submitted to IO's approval.

[53\_IO\_NB\_VVPSSBT- INFO 140] Low ferrite content (in the range of 3 to 10%) is recommended for the filler material.

[53\_IO\_NB\_VVPSSBT-R 172] Filler material used for the welding of VVPSS BOX Items and the VVPSSB Trolley, shall be procured according to RS 2000 – Tome 4 of RCC-MRX [1].

[53\_IO\_NB\_VVPSSBT- INFO 141] Data sheets for filler material are referenced in RCC-MRX (RS 2700 and RS 2900).

[53\_IO\_NB\_VVPSSBT-R 173] The filler material for the VVPSS BOX ITEMS parts and the DD Assembly Compression tool (if there is any weld), shall be qualified according to RS 5000 – Section 4 of RCC-MRX[1].

[53\_IO\_NB\_VVPSSBT-R 174] In case of use of a filler material that is not referenced in the RCC-MRX data sheets (RS 2700 and RS 2900 [1]), the supplier shall submit to IO, for acceptance, a specification data sheet mentioning the results to be obtained.

**6.7.6 Qualification of Workshops of VVPSS box Items**

[53\_IO\_NB\_VVPSSBT-R 175] For the manufacture of the VVPSS BOX Items , the technical qualification of a production workshop shall conform to RS 6000 – Tome 4 of RCC-MRX [1], “Qualification of workshops”.

**6.7.7 Weld production**

**6.7.7.1 Storage and use of the welding materials**

[53\_IO\_NB\_VVPSSBT-R 176] Regarding the VVPSS BOX Items, and the VVPSSB Trolley, all welding materials shall be stored and used according to RS 7200- Tome 4 of RCC-MRX [1].

**6.7.7.2 Preparation and Examination of Edges and Surfaces for Welding**

[53\_IO\_NB\_VVPSSBT-R 177] Prior to welding, surfaces for welding shall be clean and free from paint, oil, rust, scale, slag, grease, marking materials or other foreign materials that are detrimental during the welding cycle.

[53\_IO\_NB\_VVPSSBT-R 178] For the VVPSS BOX Items and the VVPSSB Trolley, the preparation and examination of edges and surfaces for welding shall conform to RS 7300 – Tome 4 of RCC-MRX [1].

## SUPPLY

[53\_IO\_NB\_VVPSSBT-R 179] If their inspection reveals unacceptable indication (RS 7360 [1]) a repair by grinding or other mechanical process is possible. If a repair by welding is necessary (as defined per RS 7600 [1]), a non-conformance shall be raised.

[53\_IO\_NB\_VVPSSBT-R 180] For the VVPSS BOX Items and the VVPSSB Trolley, the root opening and fit-up tolerances shall be aligned in order to comply with code requirements (RF 4300 – Tome 3 of RCC-MRX [1]), welding procedure qualification tests, non-destructive examination methods and meet final tolerances specified in the drawings

### 6.7.7.3 Execution of production welds

[53\_IO\_NB\_VVPSSBT-R 181] During production welding, The supplier shall perform supervision.

[53\_IO\_NB\_VVPSSBT-R 182] During production welding, The supplier shall inform IO of the results.

[53\_IO\_NB\_VVPSSBT-R 183] Temporary attachments e.g. the fixation of jigs, shall use compatible material (jig material in stainless steel or use of stainless steel buttering).

[53\_IO\_NB\_VVPSSBT-R 184] For the removal of temporary attachments, the supplier shall submit a method for IO acceptance.

[53\_IO\_NB\_VVPSSBT-R 185] For the removal of temporary attachments, the manufacturer shall use a method that does not damage the base material and which is compatible with cleanliness requirements.

[53\_IO\_NB\_VVPSSBT- INFO 142] Grinding is allowed only with vacuum compatible grinding wheels (see section 7.6.1 Requirements for the manufacture of Vacuum components).

[53\_IO\_NB\_VVPSSBT-R 186] Visual examination and surface examination shall be performed on the area where the temporary attachment was removed to assure permanent materials have not been gouged, nicked or otherwise damaged.

[53\_IO\_NB\_VVPSSBT-R 187] Weld surface finishing shall be compatible with the performance of non-destructive examination and vacuum requirements.

[53\_IO\_NB\_VVPSSBT-R 188] If a final cosmetic pass is used to improve weld surface finish, it shall be covered by the relevant welding procedure qualification.

[53\_IO\_NB\_VVPSSBT-R 189] Preheat and inter-pass temperatures for all welding including temporary attachment and plate edge repairs shall comply with the values specified in the related WPS.

[53\_IO\_NB\_VVPSSBT-R 190] For VVPSS BOX Items and the VVPSS B Trolley , the production of welds shall comply with RS 7400- Section 4 of RCC-MR [1].

## SUPPLY

[53\_IO\_NB\_VVPSSBT-R 191] For VVPSS BOX Items and the VVPSSB Trolley Welding, removal and inspection after removal requirements for temporary or permanent attachments shall be in accordance with RS 7420- Tome 4 of RCC-MRX [1].

### 6.7.7.4 Repair by welding

[53\_IO\_NB\_VVPSSBT-R 192] Regarding VVPSS BOX Items and the VVPSSB Trolley, the procedure to repair by welding shall follow RS 7600 and RS 7725 of Tome 4 of RCC-MRX [1].

### 6.7.7.5 Production Weld Test Coupons and Production Proof Sampling

[53\_IO\_NB\_VVPSSBT-R 193] Test coupons shall be welded in conditions representative of production welds.

[53\_IO\_NB\_VVPSSBT-R 194] Vacuum Boundary Welds, where Radiography or Ultrasonic testing is impractical (see Welds Table [60]), shall be covered by Production Proof Sampling (PPS) as per section 7.2 of [10] Vacuum Handbook Attachment 1- Welding.

[53\_IO\_NB\_VVPSSBT-R 195] Each PPS will only represent a specific type of weld and shall use the same materials, thickness and set-up as the production weld.

[53\_IO\_NB\_VVPSSBT-R 196] For VQC1A and VQC2A vacuum boundary welds, the PPS shall be welded during the same shift as the production welds and by the same welder using the same equipment to be representative of the production welding.

[53\_IO\_NB\_VVPSSBT-R 197] If more than one welder welds the production welds, each shall perform a PPS.

[53\_IO\_NB\_VVPSSBT-R 198] For VVPSS BOX Items and the VVPSSB Trolley, the production of weld test coupons shall fulfil the requirements gathered in RS 7800 [1].

### 6.7.7.6 Before welding

[53\_IO\_NB\_VVPSSBT-R 199] For VVPSS BOX Items and the VVPSSB Trolley, the requirements from RCC-MR [1] shall be followed before proceeding to the welding. This includes for information the following steps:

- Preparation of base metal including examination
- Fitting and alignment
- Cleaning of surfaces to be welded
- Checking the alignment tolerances

### 6.7.7.7 Welding documentation

## SUPPLY

[53\_IO\_NB\_VVPSSBT-R 200] In addition to the version of the Welding Data package (WDP) that will be delivered for the MMR (see section 4.3.2), a final version including the results from all the test coupons shall be submitted as part of the End of Manufacturing Report (EMR).

[53\_IO\_NB\_VVPSSBT- INFO 143] The additional documentation related to the welds is listed in chapter 4.3 and Appendix of the IVH [10].

### 6.7.7.8 *Weld related heat treatments*

[53\_IO\_NB\_VVPSSBT- INFO 144] Welded sub-assemblies of the HNB VVPSS Box and the VVPSSB Trolley can be subjected to a dimensional stability heat treatment if necessary.

[53\_IO\_NB\_VVPSSBT-R 201] If a heat treatment is necessary, it shall be performed on a subassembly prior to its final machining.

[53\_IO\_NB\_VVPSSBT- INFO 145] Post-forming or post-weld heat treatment is not required for the fabrication of austenitic stainless steel vessels.

## 6.8 Machining

[53\_IO\_NB\_VVPSSBT-R 202] The use of abrasive tools previously used with materials different from the ones foreseen for the VVPSS Box construction shall be forbidden.

[53\_IO\_NB\_VVPSSBT-R 203] Machining process shall be developed in order to minimize distortions, leading to the fulfilment of all the tolerances requirements.

[53\_IO\_NB\_VVPSSBT- INFO 146] It is recommended to clean the products just after machining to avoid dried oil on the finished surfaces.

### 6.8.1.1 *Metallic seals groove machining requirements*

[53\_IO\_NB\_VVPSSBT-R 204] To ensure vacuum sealing (with metallic seal), the machined surface finish of the sealing faces shall follow the circumferential lay of the seal.

[53\_IO\_NB\_VVPSSBT-R 205] The surface finish shall be free of surface scratches and machining defects.

[53\_IO\_NB\_VVPSSBT- INFO 147] The performance of the HELICOFLEX® seal is linked to the surface finish of the flanges. The roughness value and the method of production are involved. Optimum roughness values are given on the 2D drawings provided by IO [17] & [18]. IO recommend a serration, which follows the seal track.

### SUPPLY

If a flange design requires a manufacturing method other than lathe-turned (circular), additional polishing to create a finish that follows the seal path should be performed.

For milling machining, the 'A' method is preferred. (See picture below)

Figure 17: Machining method for Metallic seal groove

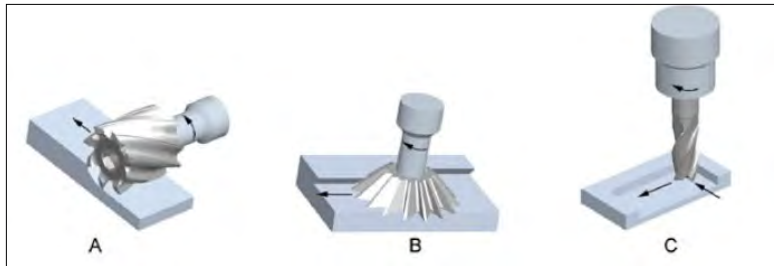

[53\_IO\_NB\_VVPSSBT-R 206] The roughness of the surfaces dedicated to metallic seals shall be as mentioned in the Build-To-Print drawings, as advised by the metallic seal manufacturer (Technetics company).

[53\_IO\_NB\_VVPSSBT-R 207] Each machining pass shall remove a very thin layer of material to ease the removal of radial scratches by polishing.

[53\_IO\_NB\_VVPSSBT-R 208] In case the surface presents (visual check) radial scratches it shall be refurbished by polishing.

[53\_IO\_NB\_VVPSSBT-R 209] Polishing shall be done following the seal track.

[53\_IO\_NB\_VVPSSBT-R 210] If the sealing surfaces have to be polished with sandpaper using a sanding block shall be made of wood or fibre as follow, :

- Use high-grade sandpaper to get rid of the milling traces
- For a final roughness value between Ra0.2 and Ra 0.8 $\mu$ m: use Grade 120 to 240 sandpaper

[53\_IO\_NB\_VVPSSBT- INFO 148] For non-grooved part, sandpaper guide made of plastic should be mounted on the part as recommended by Technetics company in order to follow the pattern of the sealing areas.

[53\_IO\_NB\_VVPSSBT-R 211] The sealing surface shall be cleaned after polishing or refurbishing to ensure that sandpaper grit general debris is removed.

[53\_IO\_NB\_VVPSSBT-R 212] The manufacturer shall use guides to follow the pattern of the sealing areas.

[53\_IO\_NB\_VVPSSBT-R 213] The manufacturer shall sand-paper the useful area (around the theoretic axis where will seat the seal).

### SUPPLY

- [53\_IO\_NB\_VVPSSBT-R 214] After manufacturing, the manufacturer shall degrease the sealing areas with alcohol.
- [53\_IO\_NB\_VVPSSBT-R 215] The seal surface shall be protected to prevent damage by scratching, Impact, machining defects, etc. until the assembly of the gaskets

## 6.9 Coating

[53\_IO\_NB\_VVPSSBT- INFO 149] Coating is required on threaded components to aid assembly/disassembly by preventing seizing of parts. Consequently, the risk of seizing a bolt and nut of similar material, in contact, is high. Coating will prevent seizing resulting from high pressure on the contact surfaces of any component under vacuum.

[53\_IO\_NB\_VVPSSBT-R 216] The material of bolts, washers and inserts under vacuum (660 grade steel) shall be treated with MoS<sub>2</sub> Coating as mentioned in the bill of material [17] & [18] .

[53\_IO\_NB\_VVPSSBT- INFO 150] MoS<sub>2</sub> coating is qualified for nuclear applications in France and used by many main Bolt Supplier (MICROFRAL 200).

[53\_IO\_NB\_VVPSSBT-R 217] For all the parts, in 660 grade to be coated with MoS<sub>2</sub>, that are mentioned in the Bills of Material [17] & [18], the Supplier shall provide a procedure for the application of the Coating to be accepted by IO.

[53\_IO\_NB\_VVPSSBT-R 218] The material of bolts, washers and inserts under atmospheric pressure (42CrM04) shall be treated with Manganese Phosphate coating as mentioned in the bill of material [17] & [18].

[53\_IO\_NB\_VVPSSBT-R 219] For all the bolts, washers and inserts in 42CrMo4, to be coated, that are mentioned in the Bills of material [17] & [18], the Supplier shall provide a procedure for the application of the Coating to be accepted by IO.

[53\_IO\_NB\_VVPSSBT-R 220] For the bolts washers and inserts under atmospheric pressure (42CrM04) belonging to the VVPSS BOX items and the VVPSSB Trolley, the Manganese Phosphate coating shall be compliant RCC-MR [1] requirements coming from section RF 5200.

## 6.10 Pickling

[53\_IO\_NB\_VVPSSBT- INFO 151] It should be noted that thermal outgassing from surfaces which have been pickled/passivated may well be greater than that from a native metal surface and may require additional baking to achieve the outgassing requirements of the ITER Vacuum Handbook.

[53\_IO\_NB\_VVPSSBT-R 221] The VVPSS Box Items classified VQC1 shall be pickled.

## SUPPLY

[53\_IO\_NB\_VVPSSBT- INFO 152] The Vacuum Handbook- Appendix 14- Guide to Passivation & Pickling for the ITER Project [55] specifies typical procedures and processes to be used when materials used for vacuum components for the ITER project need to be passivated.

[53\_IO\_NB\_VVPSSBT-R 222] Passivation & Pickling on the VVPSS BOX Items classified VQC1 components, as defined in table 1, shall follow the guidance of the Vacuum handbook – Appendix 14 - Guide to Passivation & Pickling for the ITER Project [55].

[53\_IO\_NB\_VVPSSBT- INFO 153] For the VVPSS BOX Items, the process is described in RF 6500 [1] as part of the cleaning process.

[53\_IO\_NB\_VVPSSBT-R 223] Final machining of vacuum sealing surfaces shall be left until after the pickling/passivation process.

[53\_IO\_NB\_VVPSSBT-R 224] The Supplier shall propose a procedure of passivation by aspersion in accordance with RCCMR Code.

[53\_IO\_NB\_VVPSSBT-R 225] For the RCC-MR parts (classified VQC1A), the Supplier shall propose a pickling procedure of the weld bead by paste or gel in accordance with the RCC-MRX Code.

### 6.11 Painting

[53\_IO\_NB\_VVPSSBT- INFO 154] NA

### 6.12 Manufacturability and Standardization requirements

[53\_IO\_NB\_VVPSSBT- INFO 155] Standard components are described in specific baseline documents as detailed technical specifications aiming at ensuring interchangeability of spares amongst components procured by different Suppliers. In those documents, specific components from specific Suppliers are recommended as examples of components readily available on the market that fulfil the technical specifications. The supplier has the choice of either selecting those recommended components or proposing other components under the condition that Suppliers demonstrate that they fulfil the technical specifications and interchangeability requirement.

### 6.13 Installation and Integration requirements

[53\_IO\_NB\_VVPSSBT-R 226] Bolted assembly of the VVPSS Box (Blank flange) shall be performed according to Bolt torque values specified in the VVPSS Box Analysis report [67].

[53\_IO\_NB\_VVPSSBT-R 227] The Supplier shall issue an assembly work instruction proposal for IO approval.

SUPPLY

6.14 Instrumentation and Control requirements

6.14.1 General requirements

[53\_IO\_NB\_VVPSSBT- INFO 156] Thermocouples and Heating Elements, as defined in the assembly drawing 067840, have been integrated in the 3D CATIA Model provided at PA signature.

[53\_IO\_NB\_VVPSSBT- INFO 157] As there is no possible maintenance once the VVPSS Box is installed, IO decided to double each heating element: in case of failure on one heating element, the second one can be connected in the electrical room and the complete assembly can continue to work normally. In total there will be 8 heating elements installed on the VVPSS Box and the Blank Flange. During SRO, an additional heater will be installed to cover the blank flange. Since this circuit is only temporary, it will not include redundancy.

[53\_IO\_NB\_VVPSSBT- INFO 158] The VVPSS Box is divided in 4 heating areas (see figure 9); each area is equipped with:

- 1 Operating Heating System (OHS)
- 1 Redundancy Heating System (RHS)
- 2 Thermocouples monitoring the component surface

[53\_IO\_NB\_VVPSSBT- INFO 159] Each Heating System (4 X OHS & 4 X RHS) consists in one Heating cable assembly (Heater).

Figure 18: Zoning of the Electrical Heaters

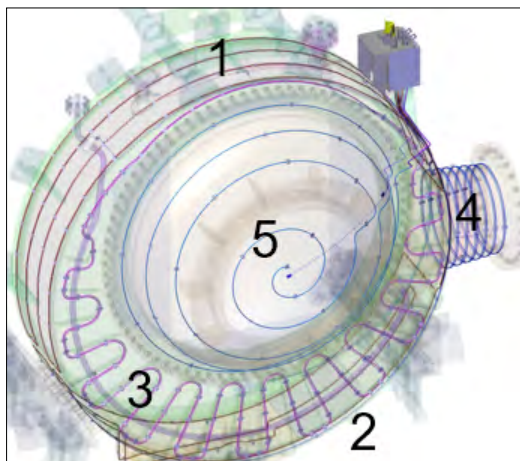

Table 11 Definition of Baking System on VVPSS Box

**SUPPLY**

See Figure 9		Zone 1	Zone 2	Zone 3	Zone 4	Zone 5
1 Operating Heating system	Heaters	1	1	1	1	1
1 Tc monitoring the component surface		1	1	1	1	1
1 Redundant Heating System	Heaters	1	1	1	1	0
1 Redundant Tc monitoring the component surface		1	1	1	1	0

*6.14.2 Common Requirement Applicable to Thermocouple Cable Assemblies and the insulated Heating cable assemblies*

[53\_IO\_NB\_VVPSSBT- INFO 160] The requirements included in this section apply to both the Thermocouples and to the Heating elements.

[53\_IO\_NB\_VVPSSBT- INFO 161] Sections 6.14.3 and 6.14.4 specify additional requirements that apply specifically to the Thermocouples or to Heating elements assemblies.

[53\_IO\_NB\_VVPSSBT- INFO 162] In the following sections of the TS, the term MICs will designate the Thermocouple and the Heating element assemblies.

**6.14.2.1 Material**

[53\_IO\_NB\_VVPSSBT-R 228] Cable Assemblies and Cables shall be made only of the materials (to the standard relevant for the initial form of the material), listed in Table 12.

Table 12 MICs material [75]

Component	Material
For the <u>cable sheath</u> , one of the following grades of Stainless Steel:	<ul style="list-style-type: none"> <li>• 316L (UNS S31603). Impurities shall not exceed any of the following limits: 0.050 weight % Cobalt; 0.010 weight % Niobium and 0.010 weight % Tantalum.</li> <li>• X2CrNiMo17-12-2. Impurities shall not exceed any of the following limits: 0.050 weight % Cobalt; 0.010 weight % Niobium and 0.010 weight % Tantalum.</li> </ul>
Cable <u>insulation</u> materials	<ul style="list-style-type: none"> <li>• Alumina with purity <math>\geq 99.55\%</math> for Cable type # A1, B1, A2, B2, A5, B5, A6, B6, A7 and B7</li> <li>• Silica with purity <math>\geq 96\%</math> for Cable type # A3, B3 and A4</li> </ul>
Cable <u>cores</u> of Cable type A6 and B6	<ul style="list-style-type: none"> <li>• Nicrosil and Nisil. Cable core(s) shall contain no coating.</li> </ul>

## SUPPLY

Component	Material
For the Cable <u>cores</u> of all other Cables, one of the following options shall be used:	<ul style="list-style-type: none"> <li>• Oxygen Free Copper (Cu-OF, CW008A, UNS C10200, JIS C1020). Cable core(s) shall contain no coating.</li> <li>• Oxygen Free Electronic Copper (Cu-OFE, CW009A, UNS C10100, JIS C1011). Cable core(s) shall contain no coating.</li> </ul>
Options for the <u>Extensions</u>	<ul style="list-style-type: none"> <li>• CuNi2Si (WNR. CW111C, UNS C64700)</li> <li>• Alumina dispersion strengthened copper alloy (UNS C15715)</li> </ul>
For the construction of the <u>terminations</u> , the following materials shall be used	<ul style="list-style-type: none"> <li>• 316L (UNS S31603) or X2CrNiMo17-12-2 No 14404. Impurities shall not exceed any of the following limits: 0.050 weight % Cobalt; 0.010 weight % Niobium and 0.010 weight % Tantalum. For the termination sleeves, only the Impurities shall not exceed any of the following limits: 1.00 weight % Cobalt; 0.20 weight % Niobium and 0.20 weight % Tantalum.</li> <li>• Nicrosil and Nisil. Cable core(s) shall contain no coating.</li> <li>• Oxygen Free Copper (Cu-OF, CW008A, UNS C10200, JIS C1020). Cable core(s) shall contain no coating.</li> <li>• Oxygen Free Electronic Copper (Cu-OFE, CW009A, UNS C10100, JIS C1011). Cable core(s) shall contain no coating.</li> <li>• Nickel Iron Alloy 42 (NILO 42 / FeNi 42) (UNS K94100, WNR 1.3917) for pins, pin reinforcing tubes and termination bodies only.</li> <li>• Kovar (UNS K94610)</li> <li>• DP1 (Dilver P1)</li> <li>• Alumina (<math>\geq</math> 92% purity)</li> <li>• Nickel 200/201 (UNS N02200 / N02201) for the pins of the special termination of Cable A4 only</li> <li>• CuNi2Si (WNR. CW111C, UNS C64700)</li> <li>• Alumina dispersion strengthened copper alloy (UNS C15715)</li> <li>• Gold, at ASTM B488 Type II Code C Class 1.27 (or equivalent); for the pins of the special termination of Cable A4 only</li> <li>• Threebond 3732 inorganic adhesive (see REQ-55-NEV0-MIC-099)</li> <li>• Resbond 908 based in alumina.</li> </ul>
<u>Braze alloys</u> used in the Cable terminations	BaAg-8 / Ag-Cu 72-28 (JIS Z3261, UNS P07720), Ag 272 (EN 17672); Nicuman 23; Nicuman 37; STEMET 1101; STEMET 1108. Additionally, and only for the A6 cable: Pure Copper Cu OFE (CuC2)
For interlayer of <u>copper coating</u>	If an interlayer for the copper coating is needed, the material to be used shall be Nickel

## 6.14.2.2 Generalities

[53\_IO\_NB\_VVPSSBT-R 229] The supplier shall design the MICs in accordance with the requirements of this technical specification.

## SUPPLY

[53\_IO\_NB\_VVPSSBT-R 230] The MICs shall be Mineral Insulated type.

[53\_IO\_NB\_VVPSSBT-R 231] The supplier shall provide the datasheets and 2D drawings (with tolerances) of the MICs.

[53\_IO\_NB\_VVPSSBT-R 232] The drawings shall contain section views of the cables detailing for each section of the cables indicating at least:

- The sheath diameter and the associated tolerance,
- The sheath thickness and the associated tolerance,
- The material of the insulant,
- The wires diameter and material,
- The distance between the wires (only for the TC)

[53\_IO\_NB\_VVPSSBT- INFO 163] The terms Compaction Rate and Void volume are both used to describe the level of compression of the insulant powder inside the cable. The relation between those 2 variables is the following:

Compaction rate = 1 – void volume

[53\_IO\_NB\_VVPSSBT-R 233] The void volume of the Cables shall be less than 30%.

### 6.14.2.3 Condition of use

[53\_IO\_NB\_VVPSSBT-R 234] The MICs shall be compliant with the following conditions of use:

- Normal operating temperature: 550°C (when baking in operation)
- Maximum temperature: 650°C

### 6.14.2.4 Manufacturing requirements

[53\_IO\_NB\_VVPSSBT-R 235] The design of the MICs shall be approved by IO before the manufacturing operations start.

[53\_IO\_NB\_VVPSSBT-R 236] Files, harsh abrasives, sand, shot or dry bead blasting, polishing pastes shall not be used on the MICs.

[53\_IO\_NB\_VVPSSBT-R 237] Neither Liquid dye penetrant (LDP) nor magnetic particle methods shall be used for testing of any of the permanent joints made during the assembly of MICs.

[53\_IO\_NB\_VVPSSBT-R 238] The MICs shall not be repaired or re-worked in case that the leak test (section 8.1.3.2) demonstrates that the leak rate exceeds the acceptable leak rate

## SUPPLY

### 6.14.2.5 Requirements related to Brazing of the MICs

[53\_IO\_NB\_VVPSSBT-R 239] If brazing is used for the manufacturing of the MICs, the brazing material shall:

- not contain Silver
- be subject to IO acceptance.

[53\_IO\_NB\_VVPSSBT- INFO 164] The section 7.6.3.1.1-“General brazing requirements for filler material” applies completely to the MICs

[53\_IO\_NB\_VVPSSBT-R 240] Where the use of brazing flux is unavoidable the cleaning shall be made :

- after application of flux and before joining the parts together,
- after joining the parts together.

### 6.14.2.6 Requirements related to welding

[53\_IO\_NB\_VVPSSBT-R 241] All welds shall be autogenous.

[53\_IO\_NB\_VVPSSBT-R 242] All welds shall be left clean and bright.

[53\_IO\_NB\_VVPSSBT-R 243] The Supplier shall prepare a welding documentation package composed of:

- A Welding and Inspection Plan
- A Welding Procedure Qualification Records (WPQR)
- A Welder Performance Qualification (WPQ)

[53\_IO\_NB\_VVPSSBT-R 244] The Welding and Inspection Plan shall specify:

- the location of each weld (descriptive drawing) with type of welds, and cross- references the supporting Welding Procedure Specification (WPS).
- The Description of welding sequence (welding manufacturing plan) including tack welding, and supporting strategy (jigs, jacks and related means of assemblies support).
- The description of welds identification/markings during the welding operations (welding map) including applicable WPSs.
- The type and scope of non-destructive examinations foreseen.
- For each welded joint:
- The dimensional sketch of the joint.
- The Number of the weld.
- The welding procedure specification (WPS) used.
- The Welder/operator and the date of welding.
- The NDT procedures used and checked.
- A Welding Procedure Specifications (WPS), providing the welder or operator specific instructions and conditions for fulfilling the welding operation.

[53\_IO\_NB\_VVPSSBT-R 245] Each WPS presented shall be supported by a Welding Procedure Qualification Record (WPQR) following the standard EN ISO 15614-1 level 1 for TIG welding and EN ISO 15614-11 for laser welding, which records the results and the parameters used during the Welding Procedure Qualification.

## SUPPLY

[53\_IO\_NB\_VVPSSBT-R 246] A Welder Performance Qualification (WPQ) shall ensure that each Individual welders is certified by a currently valid qualification test that proves they have the understanding and that demonstrate ability to work within the specified WPS (see e.g. EN ISO 9606-1: "Qualification testing of welders - Fusion welding - Part 1: Steels").

### 6.14.2.7 Marking and traceability

[53\_IO\_NB\_VVPSSBT-R 247] Each MIC shall be identified with two tags, attached near both ends.

[53\_IO\_NB\_VVPSSBT-R 248] The identification code shall be specified in English and Western Arabic Numbers.

[53\_IO\_NB\_VVPSSBT-R 249] The characters of the identification code shall have a human readable size.

[53\_IO\_NB\_VVPSSBT-R 250] The Supplier shall include the following codes in each tag:

- Functional Reference Number (FR) with the format
- For the thermocouples: 5301VB-MTE-XXXX, with XXXX as specified in the Drawing 067840.
- For the Heating elements: 5301VB-HT-XXXX, with XXXX as specified in the Drawing 067840.
- Part Number of ITER (PNI) with the format XXXXXXXXX, which will be provided during the course of the contract
- Serial Number (SN) to be provided by the Supplier.

[53\_IO\_NB\_VVPSSBT-R 251] The correlation between these three codes shall be provided by the supplier.

[53\_IO\_NB\_VVPSSBT-R 252] The tags shall fulfil the following conditions:

- Size not exceeding 60 mm x 17 mm.
- 3 rows of text written on the tag with same character height.
- minimum character height of 3mm.
- minimal distance between text rows, or with the edge of 2mm.
- Thickness not exceeding 0.2 mm.
- Tags made our non-magnetic stainless steel.
- It shall be possible to cut and remove the tag with a simple tool (e.g. cutters or pliers)
- Allows to uniquely identify each Thermocouple Cable Assembly.
- Be consistent with QA documentation and test reports.

[53\_IO\_NB\_VVPSSBT-R 253] The terminations of the Cable Assemblies shall incorporate clearly visible identification features (provided by a special shape of the termination or by markings on the termination at each conductor extension wire) allowing to identify the extension wire (Nisil and Nicosil) of each cable conductor

### SUPPLY

[53\_IO\_NB\_VVPSSBT-R 254] Each Thermocouple Sensor Cable Assembly and the Insulated Heating Cable Assembly shall be identified with two tags, attached near both ends. The identification code shall be specified in English and Western Arabic Numbers. The characters of the identification code shall have a human readable size.

#### ***6.14.2.8 Documentation to be provided before manufacturing***

[53\_IO\_NB\_VVPSSBT-R 255] Before manufacturing of the Thermocouple Cable Assembly and the Insulated Heating Cable Assembly, the Supplier shall provide at MRR for IO acceptance:

- Specific Quality plan for the Thermocouple Cable Assembly
- Manufacturing Inspection plan
- Verification Control Plan ( Supplier procedure)
- Welding procedure specification
- WPQR
- Welder's qualification reports
- Brazing procedure qualification (in case of brazing)
- Brazing flux cleaning procedure (in case brazing flux is used)
- Datasheet
- Drawing
- Preservation and storage plan
- Cleaning procedure
- Dimensional Control procedure including in particular indications about how the length of the cables are measured
- Electrical Test procedures
- Procedure for measurement of the void volumes of the cable (see section 6.14.2)
- Report on the measurement of the void volume

[53\_IO\_NB\_VVPSSBT-R 256] The Supplier shall prepare a document explaining the specific qualified cleaning procedure for brazing flux, in case the Supplier is planning to use brazing flux.

[53\_IO\_NB\_VVPSSBT-R 257] The MICs shall be subject to a MRR as described in section 5.7.4.

#### ***6.14.2.9 Documentation to be provided after manufacturing***

[53\_IO\_NB\_VVPSSBT-R 258] After manufacturing of the Thermocouple Cable Assembly and the Insulated Heating Cable Assembly, the Supplier shall provide:

- Certificate of conformity
- Material certificates (Certificate type 3.1 EN 10204)
- Welding data package
- Brazing data package (in case of brazing)
- Sheath closure X-ray + connector welding inspection report
- Dimensional inspection report
- Electrical tests report
- Leak test reports
- Cleaning reports

## SUPPLY

### 6.14.2.10 *Manufacturing controls*

[53\_IO\_NB\_VVPSSBT-R 259] The tests described in this section shall be performed on all the MICs produced, throughout manufacturing and before the components are shipped to the VVPSS Box manufacturer.

[53\_IO\_NB\_VVPSSBT-R 260] For each MIC produced, Factory Acceptance Tests shall be performed by the Supplier before the components are shipped to the final destination.

#### 6.14.2.10.1 *Compaction rate*

[53\_IO\_NB\_VVPSSBT-R 261] The compaction rate (or void volume) of the MgO shall be measured at the ends and in the middle of each reel of cable, to confirm homogeneity of the void distribution along the cable.

[53\_IO\_NB\_VVPSSBT-R 262] The Supplier shall prepare a document explaining its method to measure the compaction rate of the cable insulation.

#### 6.14.2.10.2 *Dimensional control*

[53\_IO\_NB\_VVPSSBT-R 263] On each MIC, the following dimensions shall be measured:

- the sheath diameter (for the Heating elements, the sheath diameter shall be measured in the hot and cold areas)
- the length L1, L2, and L3 (L2 and L3 only apply to the heating elements)
- the termination diameter,
- the termination length,
- the extension wires length

[53\_IO\_NB\_VVPSSBT-R 264] A macroscopic dimensional examination shall be made in one cut of each cable reel used for the production of the MICs.

[53\_IO\_NB\_VVPSSBT-R 265] The macroscopic dimensional examination shall show compliance with the dimensions and tolerances specified on the supplier 2D drawings regarding sections of cables.

#### 6.14.2.10.3 *Electrical tests*

[53\_IO\_NB\_VVPSSBT-R 266] Tests shall be performed on each MIC produced in order to measure:

- The electrical continuity,
- The total electrical resistance of the core-cable core,
- The insulation resistance (core-to-sheath),
- And the withstand voltage (cores-to-sheath).

[53\_IO\_NB\_VVPSSBT-R 267] The measured insulation resistance (cores-to-sheath) and the withstand voltage (core-to-sheath) shall be compliant with the electrical characteristics specified for each specific MIC; in section 6.14.3 for the thermocouples and section 6.14.4 the heaters.

## SUPPLY

### 6.14.2.10.4 NDT

[53\_IO\_NB\_VVPSSBT-R 268] The NDT personnel shall be qualified in accordance with ISO 9712.

[53\_IO\_NB\_VVPSSBT-R 269] A visual inspection shall be performed on the welded areas of each Thermocouple Cable Assembly and the Insulated Heating Cable Assembly.

[53\_IO\_NB\_VVPSSBT-R 270] All weld regions shall be free from scale, voids, blowholes, etc., and there shall be no visible evidence of inclusions.

[53\_IO\_NB\_VVPSSBT-R 271]

[53\_IO\_NB\_VVPSSBT-R 272] For each Thermocouple Cable Assembly and each Insulated Heating Cable Assembly, X-radiographs shall be performed to verify:  
- that there are no visible defects or cracks in welds and brazes of both terminations,  
- that the conductor twist pitch is in line with value of  $\leq 100$  mm (Not applicable for the cables that are single core)

### 6.14.2.10.5 Verification of the marking and traceability

[53\_IO\_NB\_VVPSSBT-R 273] The Supplier shall verify that the tags and conductor identification marks are visible and readable.

## 6.14.3 Specific Thermocouple Sensor cable assembly requirements

### 6.14.3.1.1 Materials

[53\_IO\_NB\_VVPSSBT-R 274] The material of the TC sensor cable assembly shall be as specified below

- Cable:
  - Sheath: Stainless Steel 316L
  - Insulant: Al<sub>2</sub>O<sub>3</sub> > 97%;
  - Conductors: TC Type N; Nisil / Nicrosil; conductors twisted (pitch  $\leq 100$  mm)
- Termination:
  - Sheath: Stainless Steel 316L
  - Insulant: Al<sub>2</sub>O<sub>3</sub> > 97%;
  - Conductor: Nisil / Nicrosil;

[53\_IO\_NB\_VVPSSBT-R 275] Nicrosil and Nisil Cable core(s) shall contain no coating.

### 6.14.3.1.2 Geometry

[53\_IO\_NB\_VVPSSBT- INFO 165] The lengths L1 is specified in tables of drawing 067840 with a tolerance of +/- 10 mm (for lengths < 5m) and +/- 0.2% (for lengths >5m).

[53\_IO\_NB\_VVPSSBT-R 276] The lengths L1 of each cable type specified in tables of drawing 067840 shall be increased by 5%.

**SUPPLY**

[53\_IO\_NB\_VVPSSBT-R 277] The external diameter of the cable of the Thermocouple assembly shall be of 1.5mm.

**6.14.3.1.3 Electrical characteristics**

[53\_IO\_NB\_VVPSSBT-R 278] The TC Sensor Cable electrical insulation shall be:

- Withstand voltage  $\geq 200$  VAC (1 minute) at room temperature
- Insulation resistance: R23°C (Resistance at 23°C)  $\geq 5$  G $\Omega$  (300 VDC)

[53\_IO\_NB\_VVPSSBT-R 279] The hot joint shall be ungrounded .

**6.14.3.1.4 Marking of the extension wires**

[53\_IO\_NB\_VVPSSBT-R 280] The terminations of the Thermocouple Cable Assemblies shall incorporate clearly visible identification features (provided by a special shape of the termination or by markings on the termination at each conductor extension wire) allowing to identify the extension wires (Nisil and Nicosil) of each cable conductor.

**6.14.3.1.5 Controls specific to the thermocouple assemblies**

[53\_IO\_NB\_VVPSSBT-R 281] Core-to-core insulation shall be verified before performing the hot joint.

**6.14.4 Specific Heater cable assembly requirements**

**6.14.4.1.1 Materials**

[53\_IO\_NB\_VVPSSBT-R 282] The material of the Heater cable assembly shall be as specified below

Cable:

- Sheath: Stainless Steel 316L
- Insulant: MgO >99.55%
- Conductor of Cold sections: One conductor - Oxygen free Copper Cu/C2 with Inconel cladding, Conductor of Hot section: Two conductors - Nickel/Chromium 80/20 alloy
- Termination:
- Sheath: Stainless Steel 316L
- Insulant: Al<sub>2</sub>O<sub>3</sub> > 97%;
- Conductors: Nisil / Nicosil;

**6.14.4.1.2 Geometry**

[53\_IO\_NB\_VVPSSBT- INFO 166] The lengths (L1, L2, and L3) of the Heating Cable Assemblies are specified in tables the drawing 067840 with a tolerance of +/- 10 mm (for lengths < 5m) and +/- 0.2% (for lengths > 5m).

## SUPPLY

[53\_IO\_NB\_VVPSSBT-R 283] The lengths L2 of each cable type specified in tables of drawing 065536 sheets 05, 07, 09 and 11 shall be increased by 5%.

[53\_IO\_NB\_VVPSSBT-R 284] The external diameter of the cable of the Heating elements assembly shall be of 5mm -0 +0.05.

### 6.14.4.1.3 Electrical characteristics

[53\_IO\_NB\_VVPSSBT-R 285] The Heaters shall be CE marked in accordance with the applicable European directives, and in particular with the Low Voltage Directive (LVD) (2014/35/EU).

[53\_IO\_NB\_VVPSSBT-R 286] The heaters shall comply with EN 62395-1 Electrical resistance trace heating systems for industrial and commercial applications – Part 1: General and testing requirements.

[53\_IO\_NB\_VVPSSBT-R 287] The insulated Heating cable Assembly shall be compliant with the following electrical values:

- Withstand voltage: 500 VAC (1 minute) at room temperature
- Insulation resistance: R23°C (Resistance at 23°C)  $\geq 5 \text{ G}\Omega$  (500 VDC) at room temperature

[53\_IO\_NB\_VVPSSBT-R 288] The Heating elements shall be compliant with the electrical power requirements specified in the table provided in the drawing 067840 under 220 V AC (when referring to utilization voltage).

## 6.15 Operation and Maintenance Requirements

### 6.15.1 Special Tools

[53\_IO\_NB\_VVPSSBT- INFO 167] The DD will be welded and bolted to the VVPSS box (see Option). The batch VVPSS box and VVPSS Box will be handled through VVPSS box interfaces.

### 6.15.2 Spare Parts

[53\_IO\_NB\_VVPSSBT- INFO 168] During the Operation phase, many of the ITER components will have to be replaced, either on a regular basis for preventive maintenance or randomly if they fail for corrective maintenance.

[53\_IO\_NB\_VVPSSBT- INFO 169] In order to maximize plant availability while containing the associated cost, and respect the timing for the scientific programme, sufficient spare parts are needed for the first assembly.

[53\_IO\_NB\_VVPSSBT-R 289] The supplier procure the spare parts defined in the BOM [17] & [18].

[53\_IO\_NB\_VVPSSBT- INFO 170] Other spares required by RAMI to address major risks, but with a short delivery time and which could be ordered and procured at the very beginning of the

### SUPPLY

Operation without undue delay, as well as spares recommended by RAMI to address medium risks, will be procured on Operation Budget and are not covered by this contract.

[53\_IO\_NB\_VVPSSBT- INFO 171] The Failure analysis study of the VVPSS Box has been performed and documented in [64].

[53\_IO\_NB\_VVPSSBT-R 290] Any change in the design of the VVPSS Box that could reduce the need for spares shall be demonstrated in an updated RAMI analysis, submitted by the supplier and subject to the approval of the IO RAMI RO.

#### 6.15.3 Training of Operators

[53\_IO\_NB\_VVPSSBT- INFO 172] The VVPSS Box does not require a training of the operators.

[53\_IO\_NB\_VVPSSBT-R 291] The VVPSSB Trolley require a training of the operators. The Supplier shall provide an operational procedure of the VVPSSB Trolley.

#### 6.16 Power supply and control command system for the VVPSS Box baking

[53\_IO\_NB\_VVPSSBT-R 292] The supplier shall define a power supply and control command system (PS&CC-S) for:

- Test of the Baking function (section 7.1.3.5)
- Hot Vacuum test (section 7.1.3.7)

[53\_IO\_NB\_VVPSSBT- INFO 173] The VVPSS Box and Blank Flange Baking has been designed by IO with the following characteristics:

- The VVPSS Box has been equipped with heating elements and thermocouples to heat up and control its temperature.
- The VVPSS Box is divided in 5 zones (see figure 19) with each zone equipped with:
- Two (one being for redundancy) heating elements (see figure 20)
- Two thermocouples (one being for redundancy) to measure the surface temperature of the zone (see figure 19)

*Figure 19: Zoning of the VVPSS Box and VVPSSB Blank Flange*

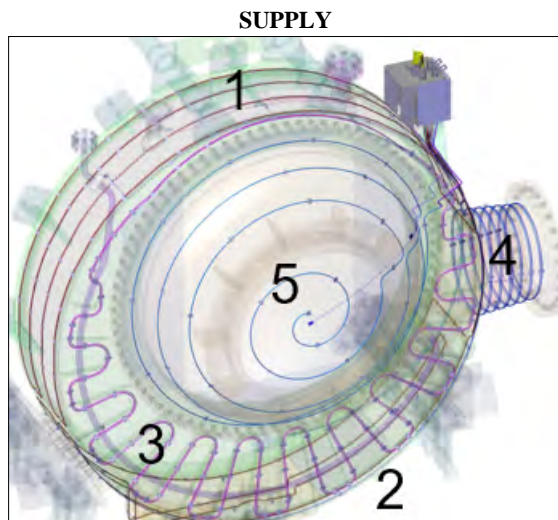

[53\_IO\_NB\_VVPSSBT- INFO 174] Thermocouples are defined in section 6.14

[53\_IO\_NB\_VVPSSBT- INFO 175] Heating elements are defined in section 6.14

[53\_IO\_NB\_VVPSSBT- INFO 176] The heating elements are designed to work under 220V AC.

[53\_IO\_NB\_VVPSSBT- INFO 177] The Baking system for ITER site has been designed by IO to be able to raise the VVPSS Box from room temperature (18°C) to the VVPSS Box baking temperature (180°C) within 2 days.

[53\_IO\_NB\_VVPSSBT- INFO 178] After turning off the Baking system, the VVPSS Box should returns naturally temperature (50°C) within 24 hours

[53\_IO\_NB\_VVPSSBT-R 293] The PS&CC-S shall allow to supply, at the same time, electrical power (see table 27):

- To each of the 6 heating elements of the zones 1, 2, 3, 4 and 5, including both main and redundant circuits.

Table 13 VVPSS Box Liner Heating Elements

VVPSS's Sub-Zone	Heater	Area Covered (m2)	Mass (kg)	Power	Heater HOT Length (m)	Heater diameter (mm)	Supply voltage (V) 1Ph	Current (A)	
				required (kW)					
1	Top	HT-0001 / HT-0002	2.03	607	0,75	17	4	220	3.4

**SUPPLY**

2	AV side	HT-0010 / HT-0011	1.94	1218	1,5	12	5	220	6.8
3	Nozzle Pipe	HT-0020 / HT-0021	0.62	214	0,4	10	4	220	1.9
4	Bottom	HT-0030 / HT-0031	1.07	595	0,75	14	4	220	3.4
5	Blank Flange	HT - 0100	< 2	607	0,75	17	4	220	3.4

[53\_IO\_NB\_VVPSSBT-R 294] The PS&CC-S shall allow to supply the heating elements considering a maximum Power used of 3 KW per heating element

[53\_IO\_NB\_VVPSSBT-R 295] The PS&CC-S shall allow to supply and control the electrical power input to each heating area independently from the other heating areas.  
 Note: only one of the two heating elements equipping the zone needs to be supplied with electrical power, but test need include both main a redundant elements.

[53\_IO\_NB\_VVPSSBT-R 296] The regulation of each zone shall be independent on the regulation of the other zones, although the set points, ramp-up and ramp-down are the same.

[53\_IO\_NB\_VVPSSBT-R 297] The regulation shall be angle phase or amplitude modulation regulation systems associated to a PID (Proportional Integral Derivative) temperature controller to drive the heat-up.

[53\_IO\_NB\_VVPSSBT-R 298] ON/OFF control regulation shall be forbidden.

[53\_IO\_NB\_VVPSSBT-R 299] The PS&CC-S shall control that each zone temperature do not differ more than 20°C between different areas.

[53\_IO\_NB\_VVPSSBT-R 300] This situation is not expected, if occurs, an alarm shall be raised to the operator and the set point of the higher temperature area shall be automatically reduced

**7 Inspection and Testing**

[53\_IO\_NB\_VVPSSBT-R 301] The Supplier shall execute inspection and testing, as requested in the applicable codes and standards, and respecting IO quality control procedure [65]. This will ensure that the procured system can meet the performances described in the SRD document [51].

[53\_IO\_NB\_VVPSSBT-R 302] The Suppliers of the component shall perform Factory Acceptance Testing, defined in the section 7.1.4, before shipping the Items to the IO.

**7.1 Examination and Tests**

### SUPPLY

[53\_IO\_NB\_VVPSSBT- INFO 179] This sub-section describes the preliminary requirements on examinations and tests to be performed on the items during manufacturing and for the Factory Acceptance Testing.

[53\_IO\_NB\_VVPSSBT-R 303] All non-destructive tests shall be carried out by suitably qualified personnel.

[53\_IO\_NB\_VVPSSBT-R 304] The results from all these tests shall be included in Manufacturer's Construction Records.

#### 7.1.1 Examination during manufacturing

##### 7.1.1.1 General requirements

[53\_IO\_NB\_VVPSSBT-R 305] Fasteners, nuts and washers shall be free of burrs and debris.

[53\_IO\_NB\_VVPSSBT-R 306] As written in Vacuum Handbook [5], for all VQC 1A, vacuum boundary welds which become inaccessible, 100% volumetric examination of production welds shall be performed (see also Table 7-2 of [5]), unless a method of preproduction proof sampling is approved.

[53\_IO\_NB\_VVPSSBT-R 307] As written in Vacuum Handbook [5], for VQC 3A boundaries (SVS connections and SVS pipes), volumetric examination of 10% of production welds shall be performed (see also Table 7-2 of [5]), unless a method of preproduction proof sampling is agreed by the ITER IO.

[53\_IO\_NB\_VVPSSBT-R 308] During the manufacturing of the VVPSS BOX Items and the VVPSSB Trolley, the NDE required by RCC-MR [1] shall be carried out. This includes the Visual Test (VT), dye or liquid Penetrant Test (PT), Ultrasonic Test (UT) or Radiography Test (RT).

[53\_IO\_NB\_VVPSSBT-R 309] The examinations of welds on the VVPSS BOX Items shall be carried out following the requirements of the RS 7720 Section 4 of RCC-MR [1] and the control methods described in Tome 3 : Examination methods of RCC-MRX [1]. See also Welds Table [84].

[53\_IO\_NB\_VVPSSBT-R 310] The examinations of welds on the VVPSSB Trolley as class N3rx shall be carried out following the requirements of the RS 7730 Tome 4 of RCC-MRX [1] and the control methods described in Tome 3: Examination methods of RCC-MRX [1].

[53\_IO\_NB\_VVPSSBT- INFO 180] For the VVPSS BOX Items, the acceptance criteria can be found in chapter RS7724 – Tome 4 of RCC-MRX [1].

### SUPPLY

[53\_IO\_NB\_VVPSSBT-R 311] For the VVPSS BOX Items, the following safety controls and tests shall be carried out:

Non-Destructive:

- Volumetric NDE: Radiographic Examination or Ultrasonic Examination as required by the RCC-MRX [1] and Vacuum Handbook [5]
- Surface NDE: Visual examination, and Liquid Penetrant Examination or Magnetic Particle Examinations as defined in the RCC-MR [1]

[53\_IO\_NB\_VVPSSBT- INFO 181] In addition, for the VVPSS BOX Items, the following tests will be carried out:

Non-Destructive:

- Vacuum Leak Detection Test (see section 7.1.3.6)

#### 7.1.1.2 Surface examination

[53\_IO\_NB\_VVPSSBT- INFO 182] The use of Liquid Dye Penetrant (LDP) is strictly regulated by the Vacuum Handbook [5] (see chapter 7.1.4).

[53\_IO\_NB\_VVPSSBT- INFO 183] On welds forming the vacuum boundary the use of liquid penetrant testing (LDP) should not in general be permitted for the inspection of welds or in the inspection of weld preparations. This is because such substances may block leaks temporarily and can be difficult to remove satisfactorily.

Where a code selected for building a component requires the use of a qualified surface examination method, and LDP cannot be avoided, only the ITER vacuum qualified liquid dye penetrant (see Appendix 4) may be used. If the use of LDP is permitted, then cleaning must be performed.

[53\_IO\_NB\_VVPSSBT-R 312] The use of LDP products shall be approved by the IO. A list of accepted LDP is given in [127].

[53\_IO\_NB\_VVPSSBT-R 313] If another fluid (not in the list) is required, a “Request for acceptance of fluid” shall be raised to the IO with the supporting qualification.

[53\_IO\_NB\_VVPSSBT- INFO 184] The use of the accepted LDP should be followed by a baking at 200°C or above for 24 hours minimum before doing the leak detection. The reason for this is that the LDP can obstruct a leak.

[53\_IO\_NB\_VVPSSBT- INFO 185] The baking is considered as a cleaning method which improves the vacuum conditioning of the area to be pumped and connected to the helium leak detector during the vacuum leak test. By reducing, the outgassing of contamination from the surfaces of the component under test the background signal at the leak detector can be reduced. Normally water is the predominant outgassing species from a clean unbaked surface. In the case that surface is contaminated (with for example Liquid Dye Penetrant) one may reasonably expect heavy hydrocarbons as the main species of contamination outgassing from the surfaces under test. Under such contamination loads, it is not generally possible to achieve a background on the leak detector pursuant with a test with the acceptance criteria stated below.

## SUPPLY

### 7.1.1.3 Volumetric examination

[53\_IO\_NB\_VVPSSBT- INFO 186] For VVPSS BOX Items and the VVPSSB Trolley , the radiographic examination is the reference volumetric examination as defined in RMC 3000 of RCC-MRX [1]

[53\_IO\_NB\_VVPSSBT-R 314] Concerning UT for VVPSS BOX Items and VVPSSB Trolley, if the process is needed, it shall follow the requirements defined in RMC 2600 of RCC-MRX [1].

### 7.1.1.4 Alternative NDE

[53\_IO\_NB\_VVPSSBT-R 315] If an alternative examination method is foreseen, it shall be qualified in accordance with the applicable manufacturing code.

[53\_IO\_NB\_VVPSSBT-R 316] The Supplier or contractor shall submit to the IO the method foreseen with supporting evidence demonstrating that the method does in fact enable the defects being tested to be identified and characterized.

### 7.1.2 Tests during manufacturing

[53\_IO\_NB\_VVPSSBT-R 317] Prior to manufacture the supplier shall have an accepted test plan detailing the timing and type of tests to be performed during manufacture. The plan shall include which tests are to be witnessed by the ITER or Domestic Agency Vacuum Specialist.

[53\_IO\_NB\_VVPSSBT- INFO 187] This test plan can for example be embedded in the control plan of each component.

#### 7.1.2.1.1 Material Procurement requirement

[53\_IO\_NB\_VVPSSBT-R 318] The Supplier shall procure material in accordance with Product Procurement Specifications or Purchase Order Specification for based material to be provided to IO for approval.

[53\_IO\_NB\_VVPSSBT- INFO 188] Positive Material PMI testing constitutes a chemical composition evaluation of the material, meeting the requirements of the Product Procurement Specification, to confirm that the material, which will be placed into service is consistent with the selected or specified grade.

[53\_IO\_NB\_VVPSSBT-R 319] PMI testing shall be performed at a point in time that ensures proper material is used in the fabrication of an identifiable assembly. Usually, this is during delivery material acceptance at Supplier's factory, fabrication or immediately prior to fabrication.

### SUPPLY

[53\_IO\_NB\_VVPSSBT-R 320] PMI testing shall not substitute required material test reports and certificates defined in section 6.4.2.

#### **7.1.2.1.2 Electrical test of Thermocouples and Heating Element Cable Assemblies prior having been mounted on the VVPSS Box & VVPSSB Flange**

[53\_IO\_NB\_VVPSSBT-R 321] Prior to the installation of MICs on the VVPSS BOX and VVPSSB Fange , the following shall be checked:

- The electrical continuity between the two ends of each TC. The criteria is the verification of the continuity.
- The insulation resistance between both end cables of the TCs and the sheath. The criteria to be verified is as follow: > 5 GΩ (300 VDC)
- The electrical continuity between both ends of each heating element. The criteria is the verification of the continuity.
- The insulation resistance between both end cables of the heating elements and the sheath of each. The criteria to be verified is as follow: > 5 GΩ (300 VDC)

#### **7.1.2.1.3 Functional test of the VVPSB Trolley**

[53\_IO\_NB\_VVPSSBT-R 322] The supplier shall test all the functions of the Trolley as defined in [61] (see section 9) .

[53\_IO\_NB\_VVPSSBT-R 323] The supplier shall study and perform a first assembly test of the VVPSS Box on the VVPSS Box Trolley

[53\_IO\_NB\_VVPSSBT-R 324] The supplier shall propose a first assembly test procedure for IO review and approval.

#### **7.1.2.1.4 Final Report on the Tests during manufacturing**

[53\_IO\_NB\_VVPSSBT-R 325] A Final Report on the Tests during manufacturing shall be provided by the Supplier to IO for acceptance at the end of the tests during manufacturing.

#### **7.1.3 Factory acceptance test**

[53\_IO\_NB\_VVPSSBT-R 326] The Factory Acceptance Test shall be done after the Tests during manufacturing (section 7.1.3) on each of the two VVPSS Boxes and the two VVPSSB Trolleys.

[53\_IO\_NB\_VVPSSBT- INFO 189] The Factory Acceptance Test comprises:

- A check of the content of the Acceptance Data Package
- A dimensional check
- A visual inspection

### SUPPLY

- A visual inspection and survey of the metallic seal and grooves
- An electrical test on the thermocouples and heating elements cable assembly
- A cold vacuum leak test
- A test of the baking function
- A hot vacuum leak test (not for the VVPSSB Trolley)
- A test of all the motions of the VVPSSB Trolley

[53\_IO\_NB\_VVPSSBT-R 327] The contractor shall provide an Inspection Test Plan.

[53\_IO\_NB\_VVPSSBT-R 328] The Inspection and Test Plan (ITP) see [65] shall include at minimum:

- the definition of the activities /inspection
- the definition of the procedure
- the criteria
- stakeholders/ participants

[53\_IO\_NB\_VVPSSBT-R 329] The supplier shall provide a procedure detailing how the FAT are performed. This procedure shall, in particular, detail the testing equipment, gigs, and tools used, as well as the particular steps of each test.

[53\_IO\_NB\_VVPSSBT-R 330] The FAT procedure shall be delivered at MRR and shall be approved by IO before the tests starts.

[53\_IO\_NB\_VVPSSBT- INFO 190] A proposal for the Leak test sequence (section 7.1.3.6) compliant with the tests specified in this section is described in the document [12].

#### **7.1.3.1 Dimensional check**

[53\_IO\_NB\_VVPSSBT- INFO 191] Dimensional controls have to be performed throughout production and at the end of manufacture as described in section 7.2.

#### **7.1.3.2 Visual examination**

[53\_IO\_NB\_VVPSSBT-R 331] Visual inspection shall be done to verify the general condition of the components and subassemblies and to identify possible defect or damage

[53\_IO\_NB\_VVPSSBT-R 332] This control shall mainly focus on the finishing and cleanliness of the surfaces exposed to vacuum or in contact with the metallic seals.

[53\_IO\_NB\_VVPSSBT-R 333] The supplier shall provide a Control Procedure document describing how the surfaces will be visually examined.

[53\_IO\_NB\_VVPSSBT-R 334] The visible surface shall be classified according to standards EN ISO 8785:1999.

[53\_IO\_NB\_VVPSSBT-R 335] Quality assurance requirements shall be clearly identified (qualification of person, work place for quality control, size of observation surface,...) in the visual Control Procedure.

## SUPPLY

[53\_IO\_NB\_VVPSSBT-R 336] The visual Control Procedure shall be submitted to IO for review.

[53\_IO\_NB\_VVPSSBT-R 337] The visual examination shall be done, at least, for the two following phases:

- After cleaning and before the leak tests of the VVPSS Box
- Before packing.

### 7.1.3.3 *Metallic seals and grooves*

[53\_IO\_NB\_VVPSSBT-R 338] The manufacturer shall inspect the groove of VVPSS BOX flanges to make sure the seal track area is free of burrs, debris and any radial marks or scratches.

[53\_IO\_NB\_VVPSSBT-R 339] Any radial scratches shall be removed by careful polishing. Deeper scratches may require re-cutting the groove and/or re-facing the flange.

[53\_IO\_NB\_VVPSSBT-R 340] The as manufactured sealing surfaces shall comply with the geometrical requirements specified in the B-t-P drawings.

[53\_IO\_NB\_VVPSSBT-R 341] A measurement survey of the groove (diameter, depth ...) shall be done.

[53\_IO\_NB\_VVPSSBT-R 342] Likewise, measurement of the roughness (Ra) of the sealing surfaces shall be done.

[53\_IO\_NB\_VVPSSBT-R 343] The dimensions of the groove and the roughness shall comply with the B-t-P drawing supplied by IO.

[53\_IO\_NB\_VVPSSBT-R 344] The seal shall be inspected for scratches and carefully handled to avoid dings, dents and radial marks or scratches.

### 7.1.3.4 *Electrical test of Thermocouples and Heating Elements Cable Assemblies*

[53\_IO\_NB\_VVPSSBT-R 345] The electrical test, described in this section, shall be performed when the VVPSS Box is fully assembled, with the blank flange installed.

[53\_IO\_NB\_VVPSSBT-R 346] The following controls shall be done on the instrumentation (TCs, Heating Elements):

- The electrical continuity between the two wires (on the thermocouples extremity located closed to the Feedthroughs passages) of each TC.  
(The criteria is the verification of the continuity)
- The insulation resistance between the wires and the sheath of each TC  
(The criteria to be verified is as follow:  $> 5 \text{ G}\Omega$  (300 VDC))
- The electrical continuity between the two wires (on the heating element extremity located closed to the Feedthroughs passages) of each heating element  
(The criteria is the verification of the continuity)
- The insulation resistance between the wires and the sheath of each heating element.

### SUPPLY

(The criteria to be verified is as follow: > 5 GΩ (300 VDC)

[53\_IO\_NB\_VVPSSBT-R 347] The following shall be checked heating up the junction of each TC:

- The TC is working (temperature is rising)

#### 7.1.3.5 Test of the Baking function

[53\_IO\_NB\_VVPSSBT-R 348] The test of baking function shall be performed:

- After the Cold Vacuum Leak Test (section 7.1.3.6)
- Under high vacuum (pressure < 1.10<sup>-6</sup> mbar) in exactly the same configuration as for the Vacuum Leak Test (section 7.1.3.7)
- After the Electrical Test of Thermocouples and Heating Elements Cable Assemblies

[53\_IO\_NB\_VVPSSBT- INFO 192] The VVPSS Box and the Blank Flange is baked using Heating Elements, and Thermocouples using the Power supply & Control Command system (see section 6.8) to regulate the baking.

[53\_IO\_NB\_VVPSSBT-R 349] The baking function test shall be performed for all the circuits i.e. both redundant circuits.

[53\_IO\_NB\_VVPSSBT- INFO 193] The VVPSS Box baking has been designed to heat the VVPSS Box and Blank Flange at a temperature greater than 180°C. The VVPSS Box has been designed to accommodate 500 baking cycles from the commissioning phase to the end of life. During D-T pulse operation, the estimated baking cycles are 40.

[53\_IO\_NB\_VVPSSBT- INFO 194] The supplier will test the Baking system designed by IO:

- to raise the VVPSS Box and the Blank Flange from room temperature (18°C) to the baking temperature (between 180°C and 200°C) within 2 days.
  - to ramp up the temperature with a rate of 5°C/hr
  - to return from the baking temperature to the pre-pulse operating temperature (50°C) within 24 hours
  - to ramp down the temperature with a rate of 6°C/hr

[53\_IO\_NB\_VVPSSBT- INFO 195] One baking test for both system ( Operating & Redundant) consists in the following:

- warm up of the components (ramp up to 180°C)
- maintain the components temperature around 180°C (24h)
- ramp down (after turning off the Baking system, the components should returns naturally temperature (50°C) within 24 hours)

[53\_IO\_NB\_VVPSSBT- INFO 196] Since the choice of the electrical heaters is an IO responsibility, in case that the electrical heaters do not allow to reach 180°C on the components,

### SUPPLY

the baking temperature will be the maximum temperature reached during the baking capability test.

[53\_IO\_NB\_VVPSSBT- INFO 197] The temperature of the VVPSS Box and the blank flange will be recorded during the whole baking cycle.

[53\_IO\_NB\_VVPSSBT- INFO 198] Data will be collected to validate the thermal models and the associated times to adjust the control functions.

#### 7.1.3.6 Vacuum Leak test (cold)

[53\_IO\_NB\_VVPSSBT-R 350] The vacuum leak test shall be carried out at ambient temperature.

[53\_IO\_NB\_VVPSSBT- INFO 199] The Vacuum Leak Test aims at validating the leak tightness of all the vacuum boundaries.

[53\_IO\_NB\_VVPSSBT-R 351] The Vacuum test requirements shall respect the requirements of the chapter 25 of the VHB [5].

[53\_IO\_NB\_VVPSSBT-R 352] The leak tests shall be conducted according to methods described in section 12.4.5.1 and 12.4.5.2 for Cold Leak Tests of Vacuum Handbook- Appendix 12 [12].

[53\_IO\_NB\_VVPSSBT- INFO 200] It is the responsibility and the interest of the Supplier to do, during the manufacturing, intermediate leak tests of the different parts so reducing risks of leakage at the last stage during the vacuum leak test when the VVPSS Box is fully assembled.

[53\_IO\_NB\_VVPSSBT-R 353] Before vacuum leak test, all vacuum surfaces shall be cleaned (see section 8.4 Cleaning).

[53\_IO\_NB\_VVPSSBT-R 354] The vacuum leak test, described in this section, shall be performed after Electrical Test of Thermocouples and Heating Elements Cables Assemblies.

[53\_IO\_NB\_VVPSSBT-R 355] The vacuum leak test shall be witnessed by IO.

[53\_IO\_NB\_VVPSSBT-R 356] The ITER Vacuum RO shall be informed a minimum of two weeks in advance of a test requiring witnessing by ITER.

[53\_IO\_NB\_VVPSSBT-R 357] The vacuum leak test results shall be added to the Acceptance Data Package.

[53\_IO\_NB\_VVPSSBT-R 358] The VVPSS Box shall be vacuum leak tested completely assembled with the Blank flange.

**SUPPLY**

- [53\_IO\_NB\_VVPSSBT-R 359] Vacuum pumps used for these processes shall be inherently clean (e.g. turbo-molecular pumps with magnetic or greased bearings, dry backing/roughing pumps, cryosorption pumps or sputter ion pumps). Otherwise, the supplier needs to satisfy ITER that a suitable failsafe trapping system has been implemented to protect against back-streaming and/or pump failure.
- [53\_IO\_NB\_VVPSSBT-R 360] The manufacturer shall provide ITER with complete details of all such equipment (including manufacturer, age, calibration certificates and history).
- [53\_IO\_NB\_VVPSSBT-R 361] No vacuum test shall be performed before ITER has accepted the use of this equipment.
- [53\_IO\_NB\_VVPSSBT- INFO 201] ITER will have the right to request documentary proof of the performance of the pumping equipment in the form of blank pump down characteristics and/or residual gas scans of the pumping equipment.
- [53\_IO\_NB\_VVPSSBT-R 362] In order to perform the vacuum leak test all apertures shall be closed:
- A closure flange has been integrated to close the VVPSS Box at the DD Bellows side.
  - The Blank Flange (Configuration SRO)
  - All connection pipes are closed with Vacuum Flanges
- [53\_IO\_NB\_VVPSSBT- INFO 202] All closure features (blank flanges) and their interfaces have been designed by IO and are part of the B-t-P package provided by IO [17].
- [53\_IO\_NB\_VVPSSBT-R 363] Some of the blank flanges shall be removed/modified to connect to the temporary vacuum system necessary for the vacuum test.
- [53\_IO\_NB\_VVPSSBT-R 364] Two Closure flanges (one for HNB1 and one for HNB2), as specified in the BOM [17] shall be provided to close the VVPSS Boxes.

*Figure 20: General views of Closure and Blank Flanges*

**SUPPLY**

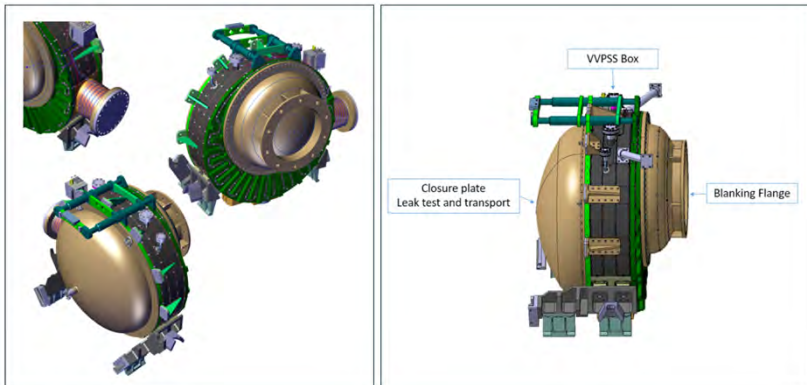

[53\_IO\_NB\_VVPSSBT-R 365] The leak tightness of the interface with the Closure flange shall use double Viton seals with a monitoring interspace, as specified in the BOM [17].

[53\_IO\_NB\_VVPSSBT-R 366] Two blank flanges (one for HNB1 and one for HNB2), as specified in the BOM [17], shall be provided to close the flange.

[53\_IO\_NB\_VVPSSBT-R 367] The leak tightness of the interface with the DD-VVPSS Closure flange shall use one single Viton seals , as specified in the BOM [17].

[53\_IO\_NB\_VVPSSBT-R 368] Closure flanges with the appropriate connexions to inject Helium , shall be designed and be installed by the supplier at the extremities of the cooling piping for these tests.

[53\_IO\_NB\_VVPSSBT- INFO 203] In the BOM [17], IO has already designed simple closure flanges to be modified as necessary by the supplier (see requirement above).

[53\_IO\_NB\_VVPSSBT-R 369] All interspaces connected to SVS, interspaces between seals, interspace between Bellows shall also be injected with helium gas.

[53\_IO\_NB\_VVPSSBT-R 370] All interspaces connected to SVS, interspaces between seals shall also be vacuum pumped with helium gas injected on the side not under vacuum.

[53\_IO\_NB\_VVPSSBT-R 371] As requested in chapter 25.5 of VHB [5] during the Cold Vacuum Tests the Cooling Pipes shall be pressurized with helium gas at their nominal pressure values:

- 2.4 MPa at temperature < 60°C

[53\_IO\_NB\_VVPSSBT-R 372] The vacuum leak test of the VVPSS BOX Items shall respect the requirements from RMC 7400 [1]

### SUPPLY

[53\_IO\_NB\_VVPSSBT-R 373] The supplier shall produce at MRR a leak test procedure for IO acceptance. The procedure shall describe how the vacuum leak test will be performed and include configuration diagrams and full details of the equipment to be used.

[53\_IO\_NB\_VVPSSBT-R 374] During the Vacuum helium leak test, the helium concentration around the test piece shall be at a minimum of 50% for the duration of the test. The helium concentration shall be measured and recorded. The helium shall be maintained for a period calculated to be sufficient to identify leaks at the acceptance level.

[53\_IO\_NB\_VVPSSBT- INFO 204] The table 25-1 of ITER Vacuum Handbook [5] defines the maximum acceptable leak rate for each NB Injector to be  $1 \times 10^{-8}$  Pa.m<sup>3</sup>/s (air equivalent). The decomposition of this general rate has been left to ITER NB section responsibility that has defined the acceptance leak rate value for the different components that compose one NB Injector in the document [113]. For one VVPSS Box, the maximum acceptable leak rate is  $1 \times 10^{-9}$  Pa.m<sup>3</sup>/s (air equivalent).

[53\_IO\_NB\_VVPSSBT-R 375] For the VVPSS Box, the maximum acceptable leak rate (from exterior atmosphere to internal vacuum) shall be less than  $1 \times 10^{-9}$  Pa.m<sup>3</sup>/s air equivalent

#### 7.1.3.7 Vacuum Leak test (Hot)

[53\_IO\_NB\_VVPSSBT- INFO 205] As specified in chapter 25.5 of ITER Vacuum Handbook [5]: "Acceptance leak tests on VQC 1A or VQC 3A components which include joints of dissimilar materials shall be subject to a minimum of three thermal cycles from ambient to the maximum possible operating temperature prior to leak testing.

[53IONBVVPSSBp1087-R] The Vacuum test requirements shall respect the requirements of the chapter 25 of the VHB [5]. => appendix 12 Leak testing  
ITER\_D\_2EYZ5F - Appendix 12 Leak Testing V1.4

[53\_IO\_NB\_VVPSSBT-R 376] The Hot Vacuum leak test shall be carried out in the same configuration as the cold vacuum leak test described in Section above

[53\_IO\_NB\_VVPSSBT-R 377] The VVPSS Box shall be vacuum leak tested completely assembled with the blank & closure flanges with all sensors (thermocouples, heating elements, connectors,) installed and connected.

[53\_IO\_NB\_VVPSSBT-R 378] The vacuum Hot leak test, described in this section, shall be performed after Baking function tests (section 7.1.3.5)

[53\_IO\_NB\_VVPSSBT-R 379] The Vacuum test requirements shall respect the requirements of the chapter 25 of the VHB [5].

[53\_IO\_NB\_VVPSSBT-R 380] Before vacuum leak test, all vacuum surfaces shall be cleaned (see section 8.4 Cleaning).

### SUPPLY

[53\_IO\_NB\_VVPSSBT-R 381] Vacuum pumps used for these processes shall be inherently clean (e.g. turbo-molecular pumps with magnetic or greased bearings, dry backing/roughing pumps, cryosorption pumps or sputter ion pumps). Otherwise, the supplier needs to satisfy ITER that a suitable failsafe trapping system has been implemented to protect against back-streaming and/or pump failure.

[53\_IO\_NB\_VVPSSBT-R 382] The vacuum leak test shall be witnessed by IO.

[53\_IO\_NB\_VVPSSBT-R 383] The vacuum leak test results shall be added to the Acceptance Data Package.

[53\_IO\_NB\_VVPSSBT- INFO 206] The hot leak test of the components consists in a series of leak test of the full components in cold hot and warm conditions.

[53\_IO\_NB\_VVPSSBT-R 384] During the hot leak test, the components shall be subject to the following detection phases:

#### Phase 1

- Test step 1 : leak test at room temperature
- Test step 2 : Leak test in warm conditions (max temperature reached during baking test section 8.1.4.6)

#### Phase 2

- Test step 3 : leak test at room temperature
- Test step 4 : Leak test in warm conditions (max temperature reached during baking test section 7.1.3.5)

#### Phase 3

- Test step 5 : leak test at room temperature
- Test step 6 : Leak test in warm conditions (max temperature reached during baking test section 8.1.4.6)

[53\_IO\_NB\_VVPSSBT-R 385] For each test step, all interspaces connected to SVS, interspaces between seals shall also be injected with helium gas.

[53\_IO\_NB\_VVPSSBT-R 386] For each test step, all interspaces connected to SVS, interspaces between seals, interspace between Bellows shall also be vacuum pumped with helium gas injected on the side not under vacuum.

[53\_IO\_NB\_VVPSSBT-R 387] The vacuum leak test of VVPSS BOX Items shall respect the requirements from RMC 7400 of RCC-MRX [1].

[53\_IO\_NB\_VVPSSBT-R 388] The supplier shall produce at MRR a leak test procedure for IO acceptance. The procedure shall describe how the Hot vacuum leak test will be performed and include configuration diagrams and full details of the equipment to be used.

### SUPPLY

[53\_IO\_NB\_VVPSSBT-R 389] During the Vacuum helium leak test, the helium concentration around the test piece shall be at a minimum of 50% for the duration of the test. The helium concentration shall be measured and recorded. The helium shall be maintained for a period calculated to be sufficient to identify leaks at the acceptance level.

[53\_IO\_NB\_VVPSSBT- INFO 207] The table 25-1 of ITER Vacuum Handbook [5] defines the maximum acceptable leak rate for each NB Injector to be  $1 \times 10^{-8}$  Pa.m<sup>3</sup>/s (air equivalent). The decomposition of this general rate has been left to ITER NB section responsibility that has defined the acceptance leak rate value for the different components that compose one NB Injector in the document [113]. For one VVPSS Box, the maximum acceptable leak rate is  $1 \times 10^{-9}$  Pa.m<sup>3</sup>/s (air equivalent).

[53\_IO\_NB\_VVPSSBT-R 390] For the VVPSS Box, the maximum acceptable leak rate (from exterior atmosphere to internal vacuum) shall be less than  $1 \times 10^{-9}$  Pa.m<sup>3</sup>/s air equivalent

[53\_IO\_NB\_VVPSSBT- INFO 208] The test will be performed assuming that the Metallic seals mounted between the VVPSS box and the Blank Flange.

[53\_IO\_NB\_VVPSSBT-R 391] The supplier shall perform the vacuum leak test, described in this section, using metallic seals for the Blank flange interfacing with the VVPSS Box.

[53\_IO\_NB\_VVPSSBT-R 392] The VVPSS Box shall be in the same configuration as described in section 7.1.3.6 (Cold Vacuum Leak Test) here above.

[53\_IO\_NB\_VVPSSBT-R 393] The leak tests shall be conducted according to methods described in section 12.4.5. for Cold Leak Tests of Vacuum Handbook-Appendix 12 [12].

[53\_IO\_NB\_VVPSSBT- INFO 209] The vacuum leak test of all the other interspaces will not need to be repeated.

[53\_IO\_NB\_VVPSSBT- INFO 210] The tests described in this section aim at validating the leak tightness of the Metallic seals Blank Flange interfacing with the VVPSS Box at the leak rate acceptance criteria defined in section 8.1.4.5 (Cold Vacuum Leak Test) .

[53\_IO\_NB\_VVPSSBT-R 394] The supplier shall produce at MRR a leak test procedure for IO acceptance before the leak test start. The procedure shall describe how the vacuum leak test with the metallic seal will be performed, and shall include configuration diagrams and full details of the equipment to be used.

[53\_IO\_NB\_VVPSSBT-R 395] During the vacuum helium leak test of the Metallic seal, the helium concentration around the test piece shall be at a minimum of 50% for the duration of the test. The helium concentration shall be measured and recorded. The helium shall be maintained for a period calculated to be sufficient to identify leaks at the acceptance level.

### SUPPLY

- [53\_IO\_NB\_VVPSSBT-R 396] Just before mounting the metallic seal between flanges, the seal shall be inspected for scratches and carefully handled to avoid dings, dents and radial marks or scratches.
- [53\_IO\_NB\_VVPSSBT-R 397] Just before mounting the metallic seal between flanges, it shall be inspected that fasteners, nuts and washer are free of burrs and debris.
- [53\_IO\_NB\_VVPSSBT-R 398] The HELICOFLEX® seal and the groove shall be cleaned carefully with acetone or alcohol using a lint free cloth.
- [53\_IO\_NB\_VVPSSBT-R 399] Before performing the test, the supplier shall provide IO with a dimensional report of the sealing surfaces (groove/ seats) of the VVPSS box and the Blank flange.
- [53\_IO\_NB\_VVPSSBT-R 400] The dimensional report of the groove/ seats of the flanges shall show compliance with the tolerances and the surface finishing requirements (see section 6.6.3.1).
- [53\_IO\_NB\_VVPSSBT-R 401] The supplier shall invite IO for witnessing the leak test of the metallic seals from preparation to conclusion.
- [53\_IO\_NB\_VVPSSBT- INFO 211] In the conclusion of the tests:
- if the leak tightness meets the criteria (the leak rate acceptance criteria defined in section 7.1.3.6 and reminded here above), then the test is considered to be completed.
  - if the leak tightness does not meet the criteria (the leak rate acceptance criteria defined in section 8.1.4.5 and reminded here above) and it is concluded between IO teams that the only technical reason for non-compliance of leak tightness is the metallic seal and seat design and/or the bolting design, then no further actions are to be carried out by the supplier. In such case, vacuum leak tests, as far as responsibility of the supplier under the contract is concerned, are considered completed.
  - In any case the responsibility of the supplier shall be completed if the Helicoflex tests are conducted in accordance with the test procedure approved by IO.
- [53\_IO\_NB\_VVPSSBT-R 402] After this test, the two VVPSS Boxes (HNB1 and 2) shall remain up to delivery (see also section 8.5.1) completely assembled with all the openings closed. This means that after each of the vacuum leak test, the closing blanks flanges, Viton seals, Helicoflex seals, temporary feedthroughs (ITER DD Feedthroughs if available) required to perform the leak test, will remain on each of the Drift-Duct with all the volumes, which have been pumped for vacuum test, backfilled with dry nitrogen or air
- [53\_IO\_NB\_VVPSSBT-R 403] After the last Vacuum test or in case of long period of time (>1 month), the volumes which have been pumped for leak testing (entire volume inside DD, including SVS and seals interspaces and bellows interspace) shall be backfilled with dry nitrogen or air (<4000 ppm H<sub>2</sub>O) at a positive pressure of 0.12 MPa and valved off.
- [53\_IO\_NB\_VVPSSBT-R 404] A calibrated check relief valve shall be installed on the VVPSS Box, during this phase so it can be guaranteed that the pressure will never exceed the pressure value of 0.12 MPa.

## SUPPLY

- [53\_IO\_NB\_VVPSSBT-R 405] The backfilling of the VVPSS box shall be done according to the requirements given in chapter 29 of VHB [5].
- [53\_IO\_NB\_VVPSSBT-R 406] Where the equipment allows manned access, air shall always be used.
- [53\_IO\_NB\_VVPSSBT-R 407] Where backfilling is not practical, alternative conditions shall be submitted to IO for acceptance by the vacuum RO.
- [53\_IO\_NB\_VVPSSBT-R 408] Air (<4000 ppm H<sub>2</sub>O) shall always be used for the main volume of the VVPSS Box.
- [53\_IO\_NB\_VVPSSBT-R 409] Dry nitrogen shall always be used for the SVS, seal interspace and bellow interspace.

### 7.1.3.8 Outgassing rate acceptance test

- [53\_IO\_NB\_VVPSSBT-R 410] Outgassing rate acceptance test shall be performed at the end of the manufacturing (after cleaning) and before the vacuum leak test, to validate the cleanliness of the component.
- [53\_IO\_NB\_VVPSSBT-R 411] Following Chapter 5.4 of VHB [5], an outgassing rate acceptance test shall be performed for all VCQ 1 components to an accepted procedure such as those described in Appendix 17 [57]
- [53\_IO\_NB\_VVPSSBT- INFO 212] Outgassing acceptance tests will be performed using representative samples or coupons (not to be delivered to IO) which follow, and are subjected to, the complete manufacturing process.
- [53\_IO\_NB\_VVPSSBT-R 412] The outgassing acceptance of material (in this case the VCQ1 VVPSS Box material) used on ITER vacuum systems shall be compliant with the values in table 5 of chapter 5.4 of VHB [5].
- [53\_IO\_NB\_VVPSSBT-R 413] The concentration of the contaminants shall also be measured following chapter 13.22.2 -General Test for Cleanliness of Vacuum Handbook - Appendix 13 [9].
- [53\_IO\_NB\_VVPSSBT- INFO 213] The Allowed concentrations of contaminants for the VVPSS Box that is classified VCQ1 are given in table 13.1 of 13.22.2 -General Test for Cleanliness - Vacuum Handbook Appendix 13 [77].
- [53\_IO\_NB\_VVPSSBT-R 414] The supplier shall produce test pieces (coupons) to measure the outgassing rate including the application of a low impurity dye penetrant surface inspection method.
- [53\_IO\_NB\_VVPSSBT-R 415] The supplier shall construct Mock-ups for the outgassing acceptance rate test on coupons to demonstrate cleanliness for high vacuum and low impurity penetrant.

## SUPPLY

[53\_IO\_NB\_VVPSSBT-R 416] The coupons shall be taken from the base material for austenitic stainless steel plates, forgings, rolled or forged bars.

[53\_IO\_NB\_VVPSSBT-R 417] The coupons shall follow the manufacturing process, proving the validity and method of the procedures proposed by the supplier.

[53\_IO\_NB\_VVPSSBT- INFO 214] The dimensions of each coupon should be 100 mm x 100 mm x 30 mm, however the size of the coupon can be larger to accommodate different welds and manufacturing processes as well with a thickness lower than 30 mm depending of the component (as example for the bellows that thickness is 1.5 mm)

[53\_IO\_NB\_VVPSSBT-R 418] The coupon shall be cut in half using the same cutting technique proposed for the VVPSS Box fabrication.

[53\_IO\_NB\_VVPSSBT-R 419] If grinding is to be used on the VVPSS box then the coupon shall be subject to the same grinding technique proposed for the DD fabrication.

[53\_IO\_NB\_VVPSSBT-R 420] The two coupon halves shall be welded using the same welding processes proposed for the VVPSS Box.

[53\_IO\_NB\_VVPSSBT-R 421] The welded coupon shall then be cleaned to the procedures described in section 8.3

[53\_IO\_NB\_VVPSSBT-R 422] The operations shall be performed on the coupons and the VVPSS Box simultaneously to ensure a representative sample

### *7.1.3.9 Functional Test of the VVPSSB Trolley*

[53\_IO\_NB\_VVPSSBT-R 423] The functional test of the VVPSSB Trolley shall be performed, when it is fully assembled.

[53\_IO\_NB\_VVPSSBT-R 424] The test sequence with the VVPSSB Trolley shall be done according to section 9 of [61].

[53\_IO\_NB\_VVPSSBT-R 425] The supplier shall provide a detailed procedure of the motion test of the VVPSSB Trolley use for IO acceptance.

### *7.1.4 Factory acceptance test Final Report*

[53\_IO\_NB\_VVPSSBT-R 426] A Factory Acceptance Test Final Report shall be provided by the Supplier to IO for acceptance at the end of the Factory Acceptance Test.

## SUPPLY

### 7.2 Metrology and Tolerances

[53\_IO\_NB\_VVPSSBT- INFO 215] This sub-section includes requirements relating to measuring the actual dimensions of the manufactured components.

[53\_IO\_NB\_VVPSSBT- INFO 216] The supplier will follow a tight control of tolerances during the manufacturing process.

[53\_IO\_NB\_VVPSSBT-R 427] The metrology shall be done after cleaning at the end of manufacturing.

[53\_IO\_NB\_VVPSSBT-R 428] The geometrical shape and tolerances shall be measured according to a testing protocol following the [13].

[53\_IO\_NB\_VVPSSBT-R 429] IO shall also be invited to witness the geometrical measurements (Hold Point).

[53\_IO\_NB\_VVPSSBT-R 430] The IO and the Supplier shall agree about the Hold Points at the critical steps of the measurements during the MRR.

[53\_IO\_NB\_VVPSSBT-R 431] All metrological and alignment operation shall be performed in accordance with the ITER Dimensional Metrology Handbook [13].

[53\_IO\_NB\_VVPSSBT- INFO 217] The dimensions and tolerances to be inspected of the VVPSS Box items and VVPSSB Trolley are considered Alignment & Metrology (A&M) class 1. The paragraph 6.4- Mandatory Requirements Procurement (MRP) for A&M Class 1 activities of [13] applies to the VVPSS Box

[53\_IO\_NB\_VVPSSBT- INFO 218] Nevertheless for the VVPSS Box items Call for Tender TS, the supplier can propose an optimization of the classification of the dimensions according to VVPSS Box items and VVPSSB Trolley functions to be agreed with IO.

[53\_IO\_NB\_VVPSSBT- INFO 219] At every important stage of the manufacturing each assembly is to be dimensionally inspected. Results are to be compared with the Accepted Manufacturing Drawings that will be produced at MRR". If necessary, remedial action is to be proposed by declaring a non-conformity.

[53\_IO\_NB\_VVPSSBT-R 432] The dimensional inspections shall be reported in the MIP.

[53\_IO\_NB\_VVPSSBT-R 433] A Dimensional Control Plan (DCP) shall be prepared and provided (according to paragraph 6.4 of [13]) during the MRR review (see section 4.3.2) approved by IO.

[53\_IO\_NB\_VVPSSBT-R 434] The DCP shall include an implementation plan defining all the quality related activities as per [MRP3] in paragraph 6.4 of [13].

## SUPPLY

### 7.2.1 Dimensional control

- [53\_IO\_NB\_VVPSSBT-R 435] All the final dimensions and geometrical tolerances specified in the DD Accepted Manufacturing Drawings and corresponding to tolerances specified in the B-t-P drawings shall be measured at the end of manufacturing.
- [53\_IO\_NB\_VVPSSBT-R 436] All the dimensions and geometrical tolerances specified in the DD Accepted Manufacturing Drawings that will be produced at MRR" shall be checked on the manufactured component.
- [53\_IO\_NB\_VVPSSBT-R 437] This data shall be presented in the Metrology report which is part of the EMR.
- [53\_IO\_NB\_VVPSSBT-R 438] This report shall comply with the requirements [MRP13] of [13].
- [53\_IO\_NB\_VVPSSBT-R 439] Tolerances of bellows shall comply with the section 7.5 of EN 14 917 [7].
- [53\_IO\_NB\_VVPSSBT-R 440] The B-t-P drawings specify dimensions at the reference temperature of 20°C. Dimensional control for factory acceptance shall be carried out in a controlled environment with a maximum temperature variation of  $\pm 2^\circ\text{C}$  as per [MRP9] of [13].
- [53\_IO\_NB\_VVPSSBT-R 441] In addition, the coordinates of the reference points shall be measured.

### 7.2.2 Roughness measurement

- [53\_IO\_NB\_VVPSSBT-R 442] For VVPSS BOX Items and the VVPSSB Trolley, the control of the surface condition or roughness shall be carried out following RMC7200 requirements [1].
- [53\_IO\_NB\_VVPSSBT-R 443] The finishing of the surfaces shall be as identified in the manufacturing drawings accepted at the MRR.
- [53\_IO\_NB\_VVPSSBT- INFO 220] Additional requirements are given in chapter 8 of VHB [5] regarding the measurement technique.

### 7.2.3 Metrology and tolerances Final Report

- [53\_IO\_NB\_VVPSSBT-R 444] A Metrology and Tolerances Final Report shall be provided by the Supplier to the IO approval at the end of the Metrology Controls.

## 7.3 Acceptance Criteria

### SUPPLY

[53\_IO\_NB\_VVPSSBT- INFO 221] The acceptance criteria for each test and for the metrology are given above in the description of the tests (section 7.1 and 7.2).

#### 7.4 Final IO site Acceptance

[53\_IO\_NB\_VVPSSBT- INFO 222] Final acceptance of the HNB VVPSS Box is done at the ITER site following delivery and execution of the IO Site Acceptance Test (SAT).

[53\_IO\_NB\_VVPSSBT- INFO 223] IO site Acceptance Testing will be carried out by IO under the responsibility of IO and with the participation of the supplier, to verify that the Items are in accordance with this TS.

[53\_IO\_NB\_VVPSSBT- INFO 224] The IO, will not open to the atmosphere the internal volume of the VVPSS Box.

[53\_IO\_NB\_VVPSSBT- INFO 225] After Delivery Report has been signed (see section 7.4), IO will organise a SAT that will start no later than 3 months from the delivery date , for the VVPSS Box:

- Checking of the back filled volumes including the backfilled internal sealed volume of the VVPSS Box and refilling in case it is necessary
- Check the external cleanliness

[53\_IO\_NB\_VVPSSBT- INFO 226] IO will fill-in a Site Acceptance Test (SAT) report that will be signed and commented (if needed) by the supplier after completion of the above checks.

[53\_IO\_NB\_VVPSSBT- INFO 227] The Final Acceptance for this procurement, alongside the transfer of ownership of the items, will be granted when:

- All the documentation (including as built drawings) described in Appendix B is delivered to the IO.
- All the tests described in this document are passed and report accepted
- All the components are delivered at the ITER site and the Site Acceptance Test(s) (SAT) are passed.
- In more detail, the Final Acceptance requires:
  - Final Acceptance of Transport Delivery Report” (see section 7.4)
  - The signature by the IO of the Delivery Report prior to shipment (see section 7.4)
  - Acceptance of Cleaning Report
  - Acceptance of the Metrology and Tolerances Final Report
  - Acceptance of the Factory Acceptance Test Final Report
  - Acceptance of the Final Report on the Tests during manufacturing
  - Acceptance of the successful Site Acceptance Test(s) (SAT) report.

[53\_IO\_NB\_VVPSSBT- INFO 228] As soon as all the above are met, IO will provide the Final Acceptance in writing to the supplier without delay.

**SUPPLY**

[53\_IO\_NB\_VVPSSBT- INFO 229] After Final Acceptance, pending installation to the ITER machine, the VVPSS Box components will be re-prepared (if necessary), by IO, to be kept in storage conditions conforming to the storage procedure delivered by the supplier (item 28 of table5).

**8 Requirements for Labelling, Cleaning, Packaging, Handling, Shipment and Storage**

**8.1 Scope of Application**

**8.2 Labelling**

*8.2.1 Identification and marking procedure*

[53\_IO\_NB\_VVPSSBT- INFO 230] The functional references (FR), as described in [78] are the following :

- 53.01.VB.VBX.0001 for the HNB1 VVPSS Box (including Flange + anchor system) [59]
- 53.01.TS.TRO.0001 (HNB1 VVPSS Box Trolley including Rails Base frame) [61]
- 53.02.VB.VBX.0001 for the HNB2 VVPSS Box (including Flange + anchor system)[59]
- 53.02.TS.TRO.0001 (HNB2 VVPSS Box Trolley including Rails Base frame) [61]

[53\_IO\_NB\_VVPSSBT- INFO 231] The Part Number of ITER (PNI), as described in [78] shall be defined for the MMR regarding the delivery strategy (number of packs) and shall be accepted by IO.

*Table 14: Labelling of VVPSS*

<b>Components</b>	<b>Functional Reference</b>	<b>Part Number Identification</b>
HNB1 VVPSS Box (including Flange + anchor system)	53.01.VB.VBX -0001	TBD for MRR
HNB1 VVPSS Box Trolley including Rails Base frame	53.01.TS.TRO.0001	TBD for MRR
HNB2 VVPSS Box (including Flange + anchor system)[	53.02.VB.VBX.0001	TBD for MRR
53.02.TS.TRO.0001	53.02.TS.TRO.0001	TBD for MRR

### SUPPLY

[53\_IO\_NB\_VVPSSBT-INFO 232] The Serial Number (SN), as described [78], is usually specified by the fabricant of the component.

[53\_IO\_NB\_VVPSSBT-R 445] The marking procedure shall comply with the IO official numbering system as per [78]

[53\_IO\_NB\_VVPSSBT-R 446] The marking of the vacuum components shall comply with the requirements of chapter 28 of Vacuum Handbook [5].

[53\_IO\_NB\_VVPSSBT-R 447] According to table 1 of [21], the supplier shall provide the Product label. The content of the label is defined in table 1 of [21].

[53\_IO\_NB\_VVPSSBT-R 448] The Product label shall be fixed to the VVPSS Box at the location defined by the supplier for the MRR. This shall be submitted to IO for approval.

[53\_IO\_NB\_VVPSSBT-R 449] The Product label shall be fixed to the VVPSSB Trolley at the location defined by the supplier for the MRR. This shall be submitted to IO for approval.

[53\_IO\_NB\_VVPSSBT-R 450] The supplier shall provide a proposal for the fixation of the Product label to IO for acceptance.

[53\_IO\_NB\_VVPSSBT-R 451] According to table 1 of [21], the supplier shall provide the Shipping label. The content of the label is defined in table 1 of [21].

#### 8.2.2 General marking requirements

[53\_IO\_NB\_VVPSSBT-R 452] The marking procedure for all the components to be delivered shall comply with RF 2000 [1]

[53\_IO\_NB\_VVPSSBT-R 453] According to VHB [5] section 28, surfaces which are to be exposed to vacuum shall only be marked or identified if necessary and shall be marked by scribing with a clean sharp point, laser scribing or electromagnetic dot peen method.

[53\_IO\_NB\_VVPSSBT-R 454] Seal faces shall not be marked in any way.

[53\_IO\_NB\_VVPSSBT-R 455] For VQC1, chemical etching shall not be used for marking unless accepted by the ITER Vacuum RO.

#### 8.3 Traceability requirements

[53\_IO\_NB\_VVPSSBT-R 456] The traceability of the materials from the arrival of the materials to the manufacturer site up to the assembly in the final products shall be guaranteed.

## SUPPLY

[53\_IO\_NB\_VVPSSBT-R 457] A traceability of materials of all components shall be established, to ensure that only correct and accepted products and parts are used during manufacturing activities.

[53\_IO\_NB\_VVPSSBT-R 458] The traceability shall be guaranteed from the reception stage to the delivery including all intermediate steps during the manufacturing route.

[53\_IO\_NB\_VVPSSBT-R 459] The material traceability shall be implemented through dedicated procedures subject to IO's approval, before starting any manufacturing operations.

[53\_IO\_NB\_VVPSSBT-R 460] The procedure of marking is not applicable to the filler material. A dedicated procedure shall be prepared by the manufacturer in accordance with the related codes and standards (RCC-MRX [1] and EN standards).

[53\_IO\_NB\_VVPSSBT-R 461] When original marking needs to be removed during the manufacturing process, it shall be transferred before being removed to ensure a permanent identification against relevant material certificates.

[53\_IO\_NB\_VVPSSBT-R 462] The RCC-MRX [1] chapter RC 1300 (see RB 1300) requires the Supplier to establish an identification and marking procedure that he shall make mandatory for all subcontractors in order to ensure the traceability of all the plates, parts or welds throughout the manufacturing process.

[53\_IO\_NB\_VVPSSBT-R 463] All permanent records of inspections shall make reference to the above markings.

### 8.4 Cleaning

[53\_IO\_NB\_VVPSSBT-R 464] The cleaning requirements shall be applicable for all the parts of the VVPSS Box and VVPSSB Trolley.

[53\_IO\_NB\_VVPSSBT- INFO 233] Care must be taken in manufacturing processes so as not to introduce contaminants which might result in degraded vacuum performance or incompatibility with the nuclear environment at ITER.

[53\_IO\_NB\_VVPSSBT- INFO 234] The following sections details the specific cleanliness requirements applicable to the manufacturing.

[53\_IO\_NB\_VVPSSBT-R 465] The requirements from chapter 24 of ITER Vacuum Handbook [5] shall apply to the VVPSS Box.

[53\_IO\_NB\_VVPSSBT-R 466] For the VVPSS Box and Blank Fange, the cleaning procedure shall follow the requirements from section 13.21 of the Vacuum Handbook - Appendix 13 Cleaning and Cleanliness [77].

[53\_IO\_NB\_VVPSSBT-R 467] For the cleaning (this section) if the requirements from [1] (RCC-MR) and [5] (VHB ) are in contradiction, the requirements from VHB Appendix 13 [77] shall prevail.

## SUPPLY

[53\_IO\_NB\_VVPSSBT- INFO 235] The document Vacuum Handbook- Appendix 13 Cleaning and Cleanliness [9] specifies typical processes which conform to the requirements of the ITER Vacuum Handbook for the cleaning of vacuum vessels, components and assemblies which are required for the ITER Project.

This covers vacuum vessels and any item which will be in a vacuum environment, whether individually or made up into assemblies containing a number of such items.

This guide is intended to assist the supplier of vacuum components to ITER in the preparation of a clean work plan and cleaning procedures for submission to ITER for acceptance. Following the guidance in this Appendix should help suppliers to achieve the requirements of the ITER Vacuum Handbook.

The supplier is at liberty to utilise other techniques not described in this Appendix provided that the components manufactured comply with the requirements of the ITER Vacuum Handbook.

[53\_IO\_NB\_VVPSSBT-R 468] The supplier shall prepare a clean work plan detailing the measures taken to comply with the requirements set out in this present specification.

[53\_IO\_NB\_VVPSSBT-R 469] All the steps of manufacturing, shall be covered by the clean work plan.

[53\_IO\_NB\_VVPSSBT-R 470] The clean work plan shall detail the specific measures, the cleaning procedures, and all of the controls that will be put in place to maintain cleanliness.

[53\_IO\_NB\_VVPSSBT-R 471] The clean work plan shall specify when these measures are applied during the manufacturing process.

[53\_IO\_NB\_VVPSSBT-R 472] The clean work plan shall be submitted to and accepted by IO before the manufacturing operations start.

[53\_IO\_NB\_VVPSSBT-R 473] The personnel working on the manufacturing of the components shall be instructed of the specific measures to ensure cleanliness of the components before manufacturing work starts.

[53\_IO\_NB\_VVPSSBT-R 474] A procedure shall be developed to ensure that the components of the VVPSS Box are cleaned to the specified requirements.

[53\_IO\_NB\_VVPSSBT-R 475] The Supplier shall submit a cleaning procedure for acceptance at the MRR.

[53\_IO\_NB\_VVPSSBT-R 476] This procedure shall include placing the components of the VVPSS Box into a clearly identified clean conditions assembly area (see section 7.4).

[53\_IO\_NB\_VVPSSBT-R 477] The surfaces of jigs, fixtures and tools that come into contact with the VVPSS Box components shall in general be constructed of stainless steel

### SUPPLY

- [53\_IO\_NB\_VVPSSBT-R 478] The surfaces of jigs, fixtures and tools that come into contact with the VVPSS Box components and VVPSSB Trolley shall never be made of carbon steel. Direct contact of carbon steel or zinc coated slings or chains, and the use of tools containing lead, bronze copper or zinc is not permitted.
- [53\_IO\_NB\_VVPSSBT-R 479] Lead or other low melting metals (tin, antimony, mercury, zinc, arsenic, cadmium, etc.) their compounds or materials containing low melting metals as a basic chemical constituent shall not be used, at any time, in direct contact with the surfaces of the component that will be exposed to vacuum. This ban includes tooling, fixtures, marking materials, dyes, paints, coating and sealing compounds used during fabrication and assembly operations.
- [53\_IO\_NB\_VVPSSBT-R 480] Tooling or equipment that produces oil, grease, flux or any substance considered a harmful contaminant shall not be permitted.
- [53\_IO\_NB\_VVPSSBT-R 481] After cleaning, all surfaces shall be “metal clean” and free from, oil, grease, ink, paint, dust, rust spots, abrasive particles, chips and any other gross discontinuities or imperfections as defined in EN-ISO(2003) 15607. All surfaces shall show a uniform metallic colour and are absent from evaporation patches from cleaning agents.
- [53\_IO\_NB\_VVPSSBT-R 482] After cleaning, Stainless steel surfaces shall be protected to avoid further contamination.
- [53\_IO\_NB\_VVPSSBT-R 483] The VVPSS Box parts and VVPSSB Trolley parts shall be wiped or brushed with solvent or alkaline detergents, rinsed with demineralised water and wiped dry with clean lint-free cloth or air dried. The use of halogenated solvents is forbidden.
- [53\_IO\_NB\_VVPSSBT-R 484] Handling equipment, such as slings, hooks, etc., shall be sheathed or protected with accepted plastic (not PVC), clean wood etc., to avoid contact of the stainless steel pieces with metallic (non S.S.) surfaces.
- [53\_IO\_NB\_VVPSSBT-R 485] Any tooling which can come in contact with the stainless steel pieces shall be made of stainless steel and cleaned before use.
- [53\_IO\_NB\_VVPSSBT-R 486] Final cleaned pieces made of stainless steel shall not be stored directly on the ground or bare floor. They shall be stored on clean surfaces, or surfaces covered with materials such as wood, plastic (not PVC), etc. No nails or resins are to be present on the wood.
- [53\_IO\_NB\_VVPSSBT-R 487] Once a component is cleaned and inspected for acceptance it shall be handled with the utmost care to preserve the cleanliness condition in preparation for packing.
- [53\_IO\_NB\_VVPSSBT-R 488] All the surfaces of the components shall be visually inspected, with the use of cameras and fibre optics if necessary, to check that the cleanliness condition is preserved.
- [53\_IO\_NB\_VVPSSBT-R 489] Prior to packing, all components shall be covered with accepted plastic film (not PVC) to avoid the accumulation of dust or unwanted debris.

### SUPPLY

[53\_IO\_NB\_VVPSSBT-R 490] PVC (polyvinyl chloride) shall not be used in contact with the parts.

[53\_IO\_NB\_VVPSSBT-R 491] During final assembly, the manufacturing operators shall wear clothing appropriate to the manipulation of clean components. This clothing shall include at least:

- Clean white overalls,
- Overshoes in the final assembly area.

[53\_IO\_NB\_VVPSSBT-R 492] The supplier shall submit proposals for achieving and maintaining these standards of cleanliness.

[53\_IO\_NB\_VVPSSBT-R 493] Prior to joining metallic part, a cleaning of these parts shall be done as required by Chapter 6.2 of VHB [5].

[53\_IO\_NB\_VVPSSBT-R 494] During assembly and cleaning, particular attention shall be given to the removal of weld spatter, debris and other foreign matter, particularly from the coolant passages and sealing surfaces.

[53\_IO\_NB\_VVPSSBT-R 495] Fasteners, nuts and washers shall be cleaned with a wire brush to remove dirt/debris on the threads or on the bearing surfaces of the hardware.

#### 8.4.1 Final cleaning requirements

[53\_IO\_NB\_VVPSSBT- INFO 236] Final cleaning is the cleaning to be done just before packing

[53\_IO\_NB\_VVPSSBT-R 496] Final cleaning shall ensure effective cleaning without damage to the surface finish, material properties or metallurgical structure of the materials.

[53\_IO\_NB\_VVPSSBT-R 497] The Supplier shall submit to IO a final cleaning procedure for acceptance at the MRR.

[53\_IO\_NB\_VVPSSBT- INFO 237] The demonstration of meeting the final cleaning requirements given in this section represents an Authorization-To-Proceed Point (ATPP).

[53\_IO\_NB\_VVPSSBT-R 498] The cleaning procedure shall follow chapter 13.11 of the Vacuum Handbook – Appendix 13 Cleaning and Cleanliness [9]. Particular care must be taken to the handling of the component after the final cleaning.

[53\_IO\_NB\_VVPSSBT- INFO 238] Great care has to be exercised when cleaning thin walled metal bellows. If any cleaning residues are trapped between the convolutions, either inside or outside, these can result in corrosion which can rapidly cause leaks to develop.

[53\_IO\_NB\_VVPSSBT- INFO 239] The requirements for the room, personnel and control to be done are described in chapter 8.4.2.

### SUPPLY

[53\_IO\_NB\_VVPSSBT-R 499] After final cleaning, the cleanliness shall be preserved using the requirement from section 8.4.2, section 8.4.3, section 8.4.4 and section 8.5 Packaging and Handling.

[53\_IO\_NB\_VVPSSBT-R 500] After cleaning, the handling of the equipment shall be strictly controlled to preserve cleanliness.

[53\_IO\_NB\_VVPSSBT-R 501] During final assembly, and after final cleaning, the components shall be handled with clean powder free latex or nitrile gloves.

#### 8.4.2 Cleanliness of work areas

[53\_IO\_NB\_VVPSSBT- INFO 240] The requirements regarding the cleanliness of work areas are defined in the following requirements:

**[53IONBVVPSSBp1274-R]** The cleanliness requirements shall comply with requirements given in chapter RF 6000 [1].

**[53IONBVVPSSBp1275-R]** The characteristics of the working area shall comply with the requirements defined in RF 6242 [1] for the work done at the factory, after application of the cleaning procedure (see section 8.4.1).

**[53IONBVVPSSBp1276-R]** The requirements from VHB [5] related to the cleanliness of the working area shall also applied.

**[53IONBVVPSSBp1277-R]** In case of the requirement above is on contradiction with VHB [5], the most severe requirements shall apply.

[53\_IO\_NB\_VVPSSBT-R 502] The working area shall be suitably segregated from other areas not fulfilling these requirements.

[53\_IO\_NB\_VVPSSBT-R 503] The working area shall be previously cleaned and cleared of ferrite materials.

[53\_IO\_NB\_VVPSSBT-R 504] The supplier shall take the appropriate measures to avoid ferrite contamination of the components.

[53\_IO\_NB\_VVPSSBT-R 505] The supplier shall take the appropriate measures to ensure cleanliness of the manufacturing area:

- Daily cleaning of the manufacturing area,
- Limited access to authorized personnel,
- Authorized equipment operated to approved procedures
- Any equipment used in the manufacturing area shall be managed adequately (e.g. no vacuum pumps or other machinery exhausting in this area)

[53\_IO\_NB\_VVPSSBT-R 506] The parts and sub-assemblies shall be stored in dedicated areas that are cleaned, cleared of ferrite material and access controlled.

### SUPPLY

- [53\_IO\_NB\_VVPSSBT-R 507] Accepted clothing shall be used in the clean area
- [53\_IO\_NB\_VVPSSBT-R 508] The use of sulphur-bearing fluids in the clean area shall be strictly controlled to minimise the risk of corrosion in stainless steel
- [53\_IO\_NB\_VVPSSBT-R 509] All items (tools, jigs and fixtures, test bench, etc.) shall be thoroughly degreased, cleaned and sealed in a suitable envelope (polythene, etc.) prior to being introduced into the clean conditions assembly area.
- [53\_IO\_NB\_VVPSSBT-R 510] An inventory of all items entering or leaving the clean area shall be maintained. This includes tools, welding machines, protective clothing (welding gloves, overshoes etc.), containers for transporting tools or components etc.
- [53\_IO\_NB\_VVPSSBT-R 511] Overhead cranes and lifting equipment shall be arranged to avoid the dripping of oil in the clean conditions assembly area
- [53\_IO\_NB\_VVPSSBT-R 512] Cutting operations in the clean area are to be minimised. Swarf generated by cutting operations shall be collected. Grinding operations should be minimized.
- [53\_IO\_NB\_VVPSSBT-R 513] Personnel working in the clean area shall be trained in the correct procedures. IO can request personnel contravening the clean area requirements are excluded from the clean area. The Supplier will re-train and, if necessary, replace the offending operative.

#### 8.4.3 Cleanliness control of the component

[53\_IO\_NB\_VVPSSBT- INFO 241] Test for cleanliness can be carried out as part of the verification of component outgassing in accordance with Vacuum Handbook -Appendix 17 [76].

[53\_IO\_NB\_VVPSSBT- INFO 242] General test for cleanliness are defined in chapter 13.22.2 of Vacuum Handbook-Appendix 13 [9] to control the cleanliness of a component.

[53\_IO\_NB\_VVPSSBT-R 514] The acceptance test for the cleanliness shall be passed satisfying the outgassing rate acceptance test as described in section 7.1.4.9

[53\_IO\_NB\_VVPSSBT- INFO 243] The control of the cleanliness class B requirements is described in chapter RF6300 of [1].

[53\_IO\_NB\_VVPSSBT-R 515] The VVPSS BOX items and the VVPSSB Trolley shall pass the test described in chapter RF 6300 of [1].

[53\_IO\_NB\_VVPSSBT-R 516] In addition for all the parts of the VVPSS Box and the Blank Flange, the cleanliness of surfaces shall be checked by:

- wiping with clean, lint-free cloth - no discolouration is acceptable
- pouring on demineralised water – the water shall spread out evenly across the surface (not form globules)

### SUPPLY

- when visual examination is impossible but surfaces are accessible for a wipe test, sufficient wipe tests in different areas are made in order to evaluate the general cleanliness level of the surface
- temper films and discolorations resulting from welding are acceptable
- outgassing test and residual gas analysis can also be used as additional information of cleanliness

[53\_IO\_NB\_VVPSSBT-R 517] The requirement above also means that intermediate cleanliness tests shall be performed throughout the manufacturing process, especially to test the cleanliness of the surfaces that become inaccessible at future stages of manufacturing (for example the surfaces inside the bellows interspace).

#### 8.4.4 Requirements related to the contamination

[53\_IO\_NB\_VVPSSBT- INFO 244] The requirements related to contamination are described in Chapter 6 of the Vacuum Handbook [5].

[53\_IO\_NB\_VVPSSBT-R 518] In addition, the chapter RF 6400 of [1] shall be applied.

#### 8.4.5 Cleaning Final Report

[53\_IO\_NB\_VVPSSBT-R 519] A Cleaning Final Report shall be provided by the Supplier to IO for approval at the end of the cleaning

### 8.5 Packaging and Handling

[53\_IO\_NB\_VVPSSBT-R 520] Any regulatory transportation requirements shall be documented and provided to the supplier prior to shipment.

[53\_IO\_NB\_VVPSSBT-R 521] The supplier shall be responsible for ensuring that the Items and associated transportation packaging satisfy the regulatory transportation requirements.

[53\_IO\_NB\_VVPSSBT-R 522] The IO shall be notified in advance in order to organize a packing inspection on factory before the transportation.

#### 8.5.1 Packing

[53\_IO\_NB\_VVPSSBT-R 523] The VVPSS Box Items shall be packed with adequate protection from thermal or mechanical stresses which may adversely affect the operation of the component VQC as specified in the chapter 29 of VHB [5] and with adequate protection from environmental exposure (as heat seal polyethylene) and transportation loads as specified in the chapter 7.2 of Tritium Handbook [8].

[53\_IO\_NB\_VVPSSBT-R 524] As mentioned in the chapter 29 of VHB [5], specific attention shall be done to protect the sealing surface.

### SUPPLY

[53\_IO\_NB\_VVPSSBT- INFO 245] As expressed in section 7.1.4.8: “After the last Vacuum Leak Test, the two VVPSS boxes (HNB1 and 2) shall remain up to delivery (see also section 8.4.1) completely assembled with all the openings closed. This means that after each of the vacuum leak test, the closing blanks flanges, Viton seals, Helicoflex seals, will remain on each of the VVPSS box with all the volumes which have been pumped for vacuum test, backfilled with dry nitrogen or air”.

[53\_IO\_NB\_VVPSSBT-R 525] The VVPSS Box shall be shipped completely assembled:  
- Blank flange mounted on the VVPSS Box.  
- All the openings closed.

[53\_IO\_NB\_VVPSSBT-R 526] This shall be done using the closing flanges and lids used for the leak test.

[53\_IO\_NB\_VVPSSBT-R 527] The Batch VVPSS box with Blank Flange (including interspace) shall be backfilled with dry nitrogen at a positive pressure of 0.12 MPa absolute and valved off.

[53\_IO\_NB\_VVPSSBT-R 528] Any temporary tools to fix all the components (if needed) for the transport shall be delivered.

[53\_IO\_NB\_VVPSSBT- INFO 246] IO will keep it for long term storage.

[53\_IO\_NB\_VVPSSBT-R 529] All the components shall be packed in storage conditions conforming to the requirements of Section 31 of [5].

[53\_IO\_NB\_VVPSSBT-R 530] The components shall be packed into its transportation case quality class 3 (QC-3) features.

[53\_IO\_NB\_VVPSSBT-R 531] The supplier shall provide a guideline document for the storage.

[53\_IO\_NB\_VVPSSBT-R 532] All Packing/Boxes shall be clearly labelled and tagged in accordance with [21].

[53\_IO\_NB\_VVPSSBT-R 533] As per table 1 of [21], on the packaging all references to the contents and other information shall be clearly shown in English language, including at least:

- 1) Title of crate,
- 2) Purchase Order, PO, Contract Number,
- PA code, etc.,
- 3) Shipping/Crate Num.,
- 4) The supplier Ref. Num.,
- 5) MN,
- 6) PNI,
- 7) SN,

### SUPPLY

- 8) Safety Classification, e.g. PIC/SIC,
- ESPN,
- 9) From (CON-M) / To,
- 10) Net / gross weight,
- 11) Responsibility,
- 12) Packing Date (MM/YYYY).

[53\_IO\_NB\_VVPSSBT-R 534] Requirements from Vacuum Handbook- Appendix 2 of [15] and 13.11 from Vacuum Handbook - Appendix 13 of [77] shall be used concerning the packing.

[53\_IO\_NB\_VVPSSBT-R 535] The items shall be properly fixed inside wooden boxes.

[53\_IO\_NB\_VVPSSBT-R 536] The boxes shall be sufficiently rigid to avoid deforming under the component weight.

[53\_IO\_NB\_VVPSSBT-R 537] Supports shall avoid the potential for impact loading on the components due to sudden movements or accidental drop.

[53\_IO\_NB\_VVPSSBT-R 538] Shock absorbing material shall be used.

#### 8.5.2 Delivery Report

[53\_IO\_NB\_VVPSSBT-R 539] Prior to send each package, a Delivery Report shall be prepared by the supplier.

[53\_IO\_NB\_VVPSSBT-R 540] The Delivery Report produced by the Supplier shall include the packaging date.

[53\_IO\_NB\_VVPSSBT-R 541] The Delivery Report produced by the Supplier shall include the full address of the place of delivery and the name of the person responsible to receive the package, as well as of the sender's name and full address.

[53\_IO\_NB\_VVPSSBT-R 542] The Delivery Report produced by the Supplier shall include the number and type of components contained in the package.

[53\_IO\_NB\_VVPSSBT-R 543] The Delivery Report produced by the Supplier shall include the enclosed documentation:

- The declaration of integrity of the package;
- The declaration of integrity of the components;
- Any additional relevant information on the status of the components.

[53\_IO\_NB\_VVPSSBT-R 544] The Delivery Report shall be signed by a representative of the Supplier.

[53\_IO\_NB\_VVPSSBT-R 545] The delivery report shall be countersigned by a representative of the IO-CT.

## SUPPLY

[53\_IO\_NB\_VVPSSBT- INFO 247] The signature by the IO-CT of the Delivery Report prior to shipment represents a Hold Point (HP).

### 8.5.3 Handling

[53\_IO\_NB\_VVPSSBT-R 546] Requirements from Vacuum Handbook- Appendix 2 [15] and 13.11 from Vacuum Handbook- Appendix 13 of [77] shall be used concerning the handling.

[53\_IO\_NB\_VVPSSBT-R 547] The Supplier shall consider all the risks and the consequent safety rules to be adopted during all the phases of packing and transport.

[53\_IO\_NB\_VVPSSBT- INFO 248] IO will be responsible for unloading on Site.

## 8.6 Shipping requirements

### 8.6.1 Generalities

[53\_IO\_NB\_VVPSSBT- INFO 249] The following generic requirements apply for the shipment of all the components to be delivered, from the manufacture/assembly site to the ITER site at the end of fabrication or to any intermediate site during the fabrication.

[53\_IO\_NB\_VVPSSBT-R 548] Suitable precautions shall be taken to avoid damage to the equipment.

[53\_IO\_NB\_VVPSSBT-R 549] The VVPSS items and the VVPSS Trolleys shall be fitted with the required accelerometers.

[53\_IO\_NB\_VVPSSBT-R 550] The VVPSS items and the VVPSS Trolleys parts shall be shipped packed, as defined below in section 8.5.

[53\_IO\_NB\_VVPSSBT-R 551] In all cases (shipment to intermediate site or ITER site) the components to be delivered (and associated tools), shall be subjected to control and inspection, as defined below in section 8.4.

### 8.6.2 Transportation and delivery to ITER site

[53\_IO\_NB\_VVPSSBT-R 552] The Items shall be delivered to the ITER site under the responsibility of the supplier.

[53\_IO\_NB\_VVPSSBT-R 553] Before the shipment, the Supplier shall prepare a Release Note in accordance with ITER Project Management and Quality Program related to the document "Contractors Release Note" [see reference 15 of [2] that will authorize the shipment when accepted by the IO.

[53\_IO\_NB\_VVPSSBT-R 554] At least two accelerometers shall be rigidly fixed onto each package.

[53\_IO\_NB\_VVPSSBT-R 555] The accelerometers shall be capable of recording the acceleration along three perpendicular directions during the full journey.

### SUPPLY

[53\_IO\_NB\_VVPSSBT- INFO 250] Before and after delivery, during and after the inspections, the components will be stored in an area fulfilling the requirements of the chapter 24.5 of [5] and in addition, for the VVPSS BOX ITEMS parts, fulfilling the requirements of the category I as described in RF 6634.1 [1].

[53\_IO\_NB\_VVPSSBT- INFO 251] In the case of anomalies the IO will make any additional relevant remark on the status and physical condition of the components.

[53\_IO\_NB\_VVPSSBT-R 556] If an inspection requirement is not passed, a non-conformance or deviation request shall be raised and submitted to the IO.

#### 8.6.3 Delivery Acceptance after transport to IO site

[53\_IO\_NB\_VVPSSBT-R 557] The maximum size of packaged items that can be transported on normal French roads to the ITER Site is; for HEL - Highly Exceptional Load: (9m wide × 9.1m high and 19m long with a weight limit of 600 tonnes) and for CEL - Conventional Exceptional Load: (5m wide × 5m high and 19m long with a weight limit of 60 tonnes).The Supplier shall ensure that all packages to be sent to ITER remain below these limits.

[53\_IO\_NB\_VVPSSBT- INFO 252] When a component arrives at the ITER site, inspection of Vacuum Equipment is requested by Vacuum Handbook (see chapter 30 of [5])

[53\_IO\_NB\_VVPSSBT-R 558] The Supplier shall deliver a Transport Delivery Report of each shipment, for IO acceptance

[53\_IO\_NB\_VVPSSBT- INFO 253] Upon receipt of the package, in presence of the carrier of the Supplier, the IO will open the package(s) and make a visual inspection of its content to check:

- The integrity of the package(s), including identifying visible damage;
- The number and type of components contained in the package(s);
- The enclosed documentation;
- The integrity of the equipment supplied.
- The reading of the accelerometers

In the case of anomalies, the IO representative will introduce the relevant additional remarks on the inspection report.

If the equipment supplied is in an acceptable condition, the IO will sign the Delivery Report and accept the delivery.

[53\_IO\_NB\_VVPSSBT- INFO 254] If the accelerometers record shocks above 5g, a thorough inspection of the components will be performed by IO with presence of the Supplier.

[53\_IO\_NB\_VVPSSBT- INFO 255] In the case whereby the components are in an acceptable condition and pass the checks, the Supplier and the IO will jointly sign the Transport Delivery Report. The signature of each of the Transport Delivery Report is an IO Hold Point.

**SUPPLY**

[53\_IO\_NB\_VVPSSBT-R 559] The Supplier shall provide to IO the original of each Transport Delivery Report.

[53\_IO\_NB\_VVPSSBT-R 560] A copy of each Transport Delivery Report shall be kept by the Supplier.

**9 Commissioning**

[53\_IO\_NB\_VVPSSBT- INFO 256] The commissioning being done on the ITER site, it is not covered by this procurement.

**10 Location for Scope of Work Execution**

[53\_IO\_NB\_VVPSSBT- INFO 257] The Contractor can perform the work at their own location

**11 IO Free issue items**

[53\_IO\_NB\_VVPSSBT- INFO 258] IO will free issue to the supplier the components specified in Table 14 in case of release of the option see section 5.5:

Component	Quantity	Drawing	Latest delivery date (link to milestones)
DD with their supporting structures and equipment to close their apertures (Option)	2	050058	To defined at the KOM regarding the Supplier schedule

Table 15: Free Issue items

[53\_IO\_NB\_VVPSSBT-R 561] The free issued items shall be installed by the supplier on the VVPSS BOX Items at the appropriate timing of the project.

**11.1 Documentation provided with the free issued items**

[53\_IO\_NB\_VVPSSBT- INFO 259] IO will provide a Transport Delivery Report of each shipment, for the supplier’s acceptance.

**11.2 Unpacking**

[53\_IO\_NB\_VVPSSBT-R 562] Unpacking by IO or its Supplier of the free issued items shall not occur without the Transport Delivery Report being provided.

[53\_IO\_NB\_VVPSSBT-R 563] Unpacking of the free issued items shall not occur without the presence of IO, or their representative, or the agreement of IO to carry on the unpacking without them.

[53\_IO\_NB\_VVPSSBT-R 564] IO, or it’s representatives shall be entitled the right to witness the unpacking of the items.

## SUPPLY

[53\_IO\_NB\_VVPSSBT-R 565] Upon reception of the package, in presence of IO (or with the IO agreement), the Supplier shall open the packages free issued by IO and make a visual inspection of their contents to check:

- o The integrity of the package(s), including identifying visible damage;
- o The number and type of components contained in each package;
- o The enclosed documentation;
- o The integrity of the equipment supplied.

[53\_IO\_NB\_VVPSSBT-R 566] In the case of anomalies, the Supplier shall introduce the relevant additional remarks on the Transport Delivery Report.

[53\_IO\_NB\_VVPSSBT-R 567] If the equipment supplied is in an acceptable condition, the Supplier shall sign the Transport Delivery Report and accept the delivery.

### 11.3 Packing

[53\_IO\_NB\_VVPSSBT-R 568] In order to preserve the components, the free issued items shall be packed just after the incoming inspection in exactly the same way they had been delivered.

### 11.4 Incoming inspection

[53\_IO\_NB\_VVPSSBT-R 569] The supplier shall perform an incoming inspection of each free issued item delivered.

[53\_IO\_NB\_VVPSSBT-R 570] After the delivery report has been signed and the associated delivery has been accepted, the supplier shall organise an incoming inspection, as soon as practicable.

[53\_IO\_NB\_VVPSSBT-R 571] The incoming inspections of the free issued items shall be performed in the presence of IO or their representatives or the agreement of IO to carry on the incoming inspection without them.

#### 11.4.1 Documentation

##### 11.4.1.1 Incoming inspection procedures

[53\_IO\_NB\_VVPSSBT-R 572] The supplier shall prepare a procedure for the incoming inspection of the components free issued under the option .

[53\_IO\_NB\_VVPSSBT-R 573] The incoming inspection procedures shall cover all the tests and inspections made during the incoming inspection.

[53\_IO\_NB\_VVPSSBT-R 574] The incoming inspection procedures shall be delivered to IO for approval.

##### 11.4.1.2 Incoming inspection reports

[53\_IO\_NB\_VVPSSBT-R 575] Upon completion of the incoming inspection of the items free issued under the option , an incoming inspection report, covering all the tests and inspections made during the incoming inspections, shall be produced by the supplier and provided to IO.

[53\_IO\_NB\_VVPSSBT-R 576] Any non-compliance of the incoming inspection acceptance criteria shall be reported in the incoming inspection reports.

## SUPPLY

[53\_IO\_NB\_VVPSSBT-R 577] Any non-compliance of the incoming inspection to the documentation provided together with the free issued items shall be reported to IO.

### 11.4.2 Incoming inspection of the components free issued

[53\_IO\_NB\_VVPSSBT-R 578] The incoming inspections of the components free issued under Option shall be performed in the presence of IO, or their representatives, or the agreement of IO to carry on the incoming inspection without them.

[53\_IO\_NB\_VVPSSBT-R 579] IO's supplier for the Drift Duct and associated components shall be entitled the right to witness the incoming inspection of the items.

[53\_IO\_NB\_VVPSSBT-R 580] The incoming inspection of each component free issued under Option free issued by IO shall consist at least of the following tests:

- A visual check in accordance with section 7.1.3.2
- A cleanliness test in accordance with section 9.4,
- A metrological check of the welding interface between the VVPSS Box and the DD,

## 11.5 Responsibilities

[53\_IO\_NB\_VVPSSBT-R 581] The supplier shall be fully responsible for the items free issued by IO after successful completion of the incoming inspection.

[53\_IO\_NB\_VVPSSBT-R 582] The supplier shall be responsible for the risk of loss, damage and destruction of the items free issued by IO after successful completion of the **inspection of the package** after its delivery (see section 11.3).

[53\_IO\_NB\_VVPSSBT-R 583] After successful completion of the **incoming inspection** (see section 11.5.5) the supplier shall be also responsible for maintaining the cleanliness of the item and avoid risks of contamination.

## 12 Deliverables and Schedule Milestones

[53\_IO\_NB\_VVPSSBT-R 584] The supplier shall deliver to IO the components (including the spare parts) listed [17] and [18] according to the contract's specified date.

[53\_IO\_NB\_VVPSSBT-R 585] The supplier shall deliver to IO any tool, jig, and support necessary for the DD manufacturing and transportation.

SUPPLY

12.1 Schedule for delivery

[53\_IO\_NB\_VVPSSBT-R 586] The schedule for delivery of the supplier shall be aligned with the dates defined in the table 16 below:

Activity	Date	Comment
HNB1 - Delivery Acceptance approved by IO for HNB1 VVPSS Box /Blank Flange/Anchor System and VVPSSB Trolley	September 2029	Assuming the signature of the contract by April 2026
HNB2 - Delivery Acceptance approved by IO for HNB1 VVPSS Box /Blank Flange/Anchor System and VVPSSB Trolley	September 2029	Assuming the signature of the contract by April 2026
Option -Free Items delivered To Supplier Workshop	February 2029	

Table 16: Schedule for Delivery

[53\_IO\_NB\_VVPSSBT- INFO 260] IO has identified a list of mandatory milestones for the project (see Appendix II) . The codes indicated in Table 1 and Table 3 are used in the naming convention of those milestones; it enables to identify to which phase and to which component a milestone is associated to.

Example: **M3.VB2** - Intermediate cleaning completed for the VVPSS Box HNB2**M** refers to an activity in the “manufacturing phase”, and **VB2** indicates that it concerns the VVPSS Box HNB2

[53\_IO\_NB\_VVPSSBT- INFO 261] The milestones listed in Appendix II can be considered as a guidance for the supplier.

[53\_IO\_NB\_VVPSSBT- INFO 262] The Contractor can propose an updated list of milestones.

[53\_IO\_NB\_VVPSSBT-R 587] The Manufacturer shall produce a detailed schedule showing all contract phases and how the overall IO Schedule complies with them.

[53\_IO\_NB\_VVPSSBT-R 588] The detailed Schedule shall be submitted to the IO for approval/acceptance before starting any work concerning the Contract.

[53\_IO\_NB\_VVPSSBT-R 589] The contractor list of milestones shall be presented to IO for approval.

[53\_IO\_NB\_VVPSSBT-R 590] The supplier shall respect the coding convention for the milestones of the project.

[53\_IO\_NB\_VVPSSBT- INFO 263] A milestone will be considered as reached when all the following conditions are met:

- The activities preceding the milestone (and corresponding to it) were completed,
- All the deliverable documentation associated to the milestone has been approved by IO.

## SUPPLY

### 12.2 List of deliverable documentation

[53\_IO\_NB\_VVPSSBT-R 591] The Supplier shall provide IO with the documents and data required in the application of this technical specification – See Appendix I , the GM3S Ref [1] and any other requirement derived from the application of the contract.

Supplier shall prepare their document schedule based on the above and using the template available in the GM3S Ref [1] appendix II ([click here to download](#)).

### 13 Quality Assurance requirements

[53\_IO\_NB\_VVPSSBT- INFO 264] The Quality class under this contract is QC1 [2] GM3S section 8 applies in line with the defined Quality Class.

[53\_IO\_NB\_VVPSSBT-R 592] Quality Requirements shall be in accordance with the “ITER Procurement Quality Requirements” [23].

[53\_IO\_NB\_VVPSSBT-R 593] The ITER Quality Assurance Program shall be applied to all the work under this Contract. The ITER QA Program is based on IAEA Safety Standard GS-R-3 and conventional QA principles and integrates the requirements of the INB Order dated 7 February 2012 [28] on the quality of design, construction, and operation in Basic Nuclear Installation.

[53\_IO\_NB\_VVPSSBT-R 594] For this purpose, the Supplier and Subcontractors carrying out contracts placed under this Contract shall be in compliance with the QA requirements under the relevant ITER QA classifications, the requirements of the INB Order, and shall have an IO-approved QA Program or an ISO 9001 accredited quality system, complemented with the above-mentioned requirements.

[53\_IO\_NB\_VVPSSBT-R 595] Prior to the commencement of any work under this Contract, a “Quality Plan”(QP) [24] shall be produced by the Supplier and Subcontractors and submitted to the IO for approval, describing how they will implement the ITER Procurement Quality Requirements.

[53\_IO\_NB\_VVPSSBT-R 596] As part of the Quality plan, the manufacturer shall identify potential risks related to the contract and provide the associated Risk plan/register.

[53\_IO\_NB\_VVPSSBT-R 597] Prior to the commencement of any manufacturing, a “Manufacturing and Inspection Plan” (MIP) [25] shall be produced by the Supplier and Subcontractors and approved by the IO, which will mark up any intended intervention point. MIPs are used to monitor Quality Control and acceptance tests during the execution of the Contract. It should be noted that interventions additional to those required in this Technical Specification may be included on the MIP by the IO.

### SUPPLY

- [53\_IO\_NB\_VVPSSBT-R 598] The right of the IO listed above shall apply in relation to any Subcontractor, and in this case, the IO will operate through the Supplier. The overseeing of the quality control operation by the IO shall not release the Supplier from his responsibility in meeting any aspect of this Technical Specification. Subcontractors not performing Critical Quality Activities (i.e. activities that, if not performed correctly, may affect safety, functionality, or reliability) may be exempted from the requirement to supply Quality Plans and Manufacturing & Inspection Plans, subject to agreement by the IO.
- [53\_IO\_NB\_VVPSSBT-R 599] All requirements of this Technical Specification and subsequent changes proposed by the Supplier during the execution of this Contract shall be subject to the Deviation Request process described in “Contractors Deviations [34] and Non-conformities Procedure” [26].
- [53\_IO\_NB\_VVPSSBT-R 600] Documentation developed as the result of this Contract shall be retained by the Supplier for a minimum of 5 years and then may be discarded at the direction of the IO.
- [53\_IO\_NB\_VVPSSBT-R 601] The use of computer software to perform a safety-based task activity, such as analysis and/or modelling, etc. shall be reviewed and approved by the IO before its use following “Quality Assurance for ITER Safety Codes Procedure” [29].
- [53\_IO\_NB\_VVPSSBT-R 602] In case of Contracts concerning Safety Related Activity, or Protection Related Activities, the Quality Assurance Program of the Supplier shall comply with the requirements of the INB Order dated 7 February 2012 [28] and the subsequent ASN decisions linked to this Order.
- [53\_IO\_NB\_VVPSSBT-R 603] For this purpose, the Supplier and Subcontractors carrying out contracts placed under the Contract shall comply with the QA requirements under the relevant QA classifications as defined in “Quality Classification Determination” [31] and additional requirements of the INB Order dated 7 February 2012 [28] and the subsequent ASN decisions linked to this Order.
- [53\_IO\_NB\_VVPSSBT-R 604] In particular for SIC, the IO, as the Nuclear Operator, will supervise the whole production cycle of the Supplier and Subcontractors in accordance with the document “Overall Supervision Plan of the Chain of Suppliers for Safety Important Components, Structures and Systems and Systems and Safety Related Activities” [30], which shall be identified in the MIP [25].

## 14 Special Management requirements

- [53\_IO\_NB\_VVPSSBT-R 605] Requirement for [2] GM3S section 6 shall apply in full.

## SUPPLY

### 14.1 Work Monitoring

[53\_IO\_NB\_VVPSSBT-R 606] In accordance with [2], the Supplier shall establish an executive project team covering as a minimum the following functions:

- Delivery Project management,
- Project planning and control,
- Production engineering (including functions for CAD, Welding, NDE and Metrology),
- Procurement/purchases,
- Engineering management,
- Documentation management,
- QA,
- QC (including NCR management),
- Nuclear Safety and Risk.

[53\_IO\_NB\_VVPSSBT- INFO 265] The Supplier may propose other sharing of functions among project disciplines for IO to review and accept.

[53\_IO\_NB\_VVPSSBT-R 607] In accordance with [2], the Supplier shall be responsible of the preparation of the Supplier equipment, buildings and facilities, recruiting and mobilizing staffing and consolidating processes within the Supplier and with the key subcontractors and partners, in such a way that appropriate resources become available for the WP\_E1 (Engineering), WP\_Q2 (Qualification), WP\_P3 (Procurement), WP\_M4 (Manufacturing), WP\_T5 (Factory Acceptance Test) and WP\_D6 (Delivery) timely, in accordance with the resource plan presented at tender stage for the relevant WBS.

[53\_IO\_NB\_VVPSSBT-R 608] In accordance with [2], the Supplier shall establish adequate project execution plan, project monitoring, project control, reporting and communication plan among IO, Supplier and subcontractors.

[53\_IO\_NB\_VVPSSBT-R 609] In accordance with [2], the Supplier shall manage the contract performance and schedule.

[53\_IO\_NB\_VVPSSBT-R 610] In Accordance with [2], the Supplier shall maintain a reporting calendar of the main recurrent

[53\_IO\_NB\_VVPSSBT-R 611] The Supplier shall ensure a close oversight of the production of its Suppliers and Subcontractors in accordance with an internally approved Manufacturing and Inspection Plan (MIP) accepted by IO

[53\_IO\_NB\_VVPSSBT-R 612] This monitoring shall include the preliminary list of Notification Points, Authorization-To-Proceed Points, Hold Points and Witness Points at critical steps in the Suppliers' plans (see Table 10).

**SUPPLY**

[53\_IO\_NB\_VVPSSBT- INFO 266] IO will define the final control points when the manufacturing plan, MIPs and associated drawings are submitted.

[53\_IO\_NB\_VVPSSBT-R 613] The Control Points shall be integrated into the agreed schedule and MIPs.

[53\_IO\_NB\_VVPSSBT-R 614] The Supplier shall prepare a **Factory Rolling Wave Planning** (FRWP) including the activities developed in the all the workshops.

[53\_IO\_NB\_VVPSSBT-R 615] The FRWP shall be first sent when workshop activities start and as a minimum shall contain the listing of activities and brief description of the work to be done in each workshop, including subcontractors.

[53\_IO\_NB\_VVPSSBT-R 616] The time span of the FRWP shall be not less than 6 weeks and shall be monthly updated and send it to IO for information.

[53\_IO\_NB\_VVPSSBT-R 617] The information can be displayed in form of a table indicating the next activities on the workshops and the expected starting and finishing dates for the activities to be carried out during the 6 weeks duration of the FRWP.

[53\_IO\_NB\_VVPSSBT-R 618] The FRWP shall identify (by means of a specific column, for instance) the criticality of each activity, if this is the case (i.e. HPs, PIA, TC, Class 1 dimension, etc...).

[53\_IO\_NB\_VVPSSBT-R 619] The Manufacturer shall provide the IO with a monthly progress report on all works under this contract by the 5th calendar day of each month using the standard template [32] and agree on periodic review meetings to monitor contract execution.

[53\_IO\_NB\_VVPSSBT-R 620] The Manufacturer shall report to the IO as soon as possible any occurrence that could delay or jeopardize the proper execution of activities related to this contract.

[53\_IO\_NB\_VVPSSBT-R 621] Project progress meetings shall be conducted based on mutual agreement, with the frequency varying throughout the tender's progress, typically from once per month in the initial phase to once per three months towards the end. The meetings may be conducted through video/teleconferencing or in-person discussion at the supplier's premises.

[53\_IO\_NB\_VVPSSBT-R 622] In case of specific needs for technical or contractual discussions, ad-hoc meetings could also be organized.

[53\_IO\_NB\_VVPSSBT-R 623] The Manufacturer shall prepare the project progress meeting minutes within seven (7) days and submit them to the IO.

**SUPPLY**

- [53\_IO\_NB\_VVPSSBT-R 624] The Manufacturer shall ensure that the IO representatives are granted access to the suppliers' premises and sub-suppliers to witness on-site tests and critical fabrication operations and participate in periodic review meetings at any time for witnessing and for the periodic review meeting, free of charge.
- [53\_IO\_NB\_VVPSSBT-R 625] IO representative shall also be granted access at all reasonable times to carry out on-the-spot checks in addition to the tests foreseen in the technical specifications.
- [53\_IO\_NB\_VVPSSBT-R 626] IO shall ensure that the Manufacturer and suppliers are granted appropriate access rights to the IO site.
- [53\_IO\_NB\_VVPSSBT-R 627] The supplier shall allow the IO to photograph the ITER equipment during the contract execution at the supplier's premises.
- [53\_IO\_NB\_VVPSSBT-R 628] For the supply of items under this contract, the Manufacturer shall ensure that TPIA (appointed by IO) is granted free and appropriate access to their site and its subcontractor's facilities where this component is being manufactured to records for surveillance, inspection (including unscheduled inspections) or audit as requested by them under the applicable national laws and regulations.
- [53\_IO\_NB\_VVPSSBT-R 629] The Manufacturer shall ensure that the ASN is granted free and appropriate access to their site and its sub-contractors.

**14.2 Meeting Schedule**

- [53\_IO\_NB\_VVPSSBT-R 630] As defined in [2] GM3S section 6.1.4.2, The Contractor shall prepare on a monthly basis a progress report using the template as per Appendix IV of [2]. This report is to be submitted at minimum one (1) week prior to the monthly progress meeting to IO.
- [53\_IO\_NB\_VVPSSBT-R 631] Requirement for [2] GM3S section 6.1.6 shall apply in full.
- [53\_IO\_NB\_VVPSSBT-R 632] The IO shall organize reviews and status /Quality control reviews by mutual agreement at various execution stages. These may be focused on different manufacturing stages and particular areas of production. If required, IO will appoint the review group and define its terms of reference.

*Table 17 Main reviews*

No	Type of review	Remarks
1	Manufacturing Readiness Review (MRR)	[62]
2	Approval of pre-manufacturing documents (Manufacturing drawings, Quality Plans, MIP, and Procedure)	
3	Project progress review	Periodic reviews as per mutual convenience
4	Delivery readiness reviews	[33]

**SUPPLY**

**14.3 CAD design requirements**

[53\_IO\_NB\_VVPSSBT-R 633] This contract requires for CAD activities, [2] GM3S section 6.2.2.2 be applied

[53\_IO\_NB\_VVPSSBT- INFO 267] See section 5.2.5.2

**15 Appendices**

### Appendix I – List of Deliverable Supplies

[53\_IO\_NB\_VVPSSBT- INFO 268] The List of deliverables of the Supplier (list of documents and data to be provided by the Supplier) is defined in the table 14.

[53\_IO\_NB\_VVPSSBT- INFO 269] The following table 14 summarizes most of the documents and files to be delivered by the Supplier in the frame of the contract.

Table 18 – List of deliverables

Phases	WBS Name	Document Title	Comments
<b>Tendering for manufacturing</b>			
Offer reception		Technical offers	
<b>WP_PM0 – Project management and Quality</b>			
	PM0-XXX	PQMP and schedule baseline	
	PM0-XXX	The Supplier Risk management Plan (provided at kick off meeting)	
	PM0-XXX	workshop qualification (shop qualification report / product & part qualification report as per RCC-MR requirements)	
<b>WP_E1 – Engineering</b>			
All documentations defined in table 5 of the TS	E1-XXXX	Schedule	To Be Discussed during the Kick of meeting of the manufacturing contract according to list of documents to be provided at the MRR.
	E1-XXXX	Manufacturing drawings	
	E1-XXXX	Material certificates	
	E1-XXXX	Fabrication shop description	
	E1-XXXX	MIP VVPSS BOX	
	E1-XXXX	MIP VVPSS Blank Flange	
	E1-XXXX	MIP VVPSS Anchor system	
	E1-XXXX	MIP VVPSSB Trolley	
	E1-XXXX	Welding Data book	

	E1-XXXX	WPS / PQR/ WPQR Status	
	E1-XXXX	NDE feasibility report	
	E1-XXXX	Distortion Management Plan (defined in this section)	
	E1-XXXX	Non Destructive Examination (NDE) procedure	
	E1-XXXX	Equipment identification (PNI*)	
	E1-XXXX	Material identification	
	E1-XXXX	Marking procedure	
	E1-XXXX	Traceability procedure	
	E1-XXXX	Dimensional checking procedure / Dimensional Control Plan (DCP)	
	E1-XXXX	Heat Treatment Procedure	
	E1-XXXX	Pickling and Passivation Procedure	
	E1-XXXX	Cleaning Procedure / Clean condition work plan	
	E1-XXXX	Factory Acceptance Tests procedures (see section 7.1.3)	
	E1-XXXX	Tests procedure for the Pressure Test (see section 8.1.2.2)	
	E1-XXXX	Packing procedure	
	E1-XXXX	Storage procedure	
	E1-XXXX	Transportation procedure	
<b>WP_Q2 – Qualifications and factory preparation</b>			
	Q2-XXX	Welding/machining inspection and test report	
<b>WP_P3 - Procurement</b>			
	P3-XXX	material certificates	
<b>WP_M4 – Manufacturing</b>			
Welds / Welds inspection	M4-XXX	Update Welding Data book	
	M4-XXX	WPS / PQR/ WPQR	
	M4-XXX	Welding monitoring sheets	
	M4-XXX	RT Examination reports and films	
	M4-XXX	Liquid Dye Penetrant Examination reports	
	M4-XXX	Visual Examination reports	

	M4-XXX	Alternative NDE and reports	if needed
Other reports	M4-XXX	He Leak (intermediate if any before FAT) detection examination reports	
	M4-XXX	Pressure test reports	
	<b>WP_T5 – Factory Acceptance Testing</b>		
	T5-XXX	Inspection (metrology and visual) report	The IO acceptance of the documentation clear the HP
	T5-XXX	Final cleaning report	The IO acceptance of the report clear the HP
	T5-XXX	Outgassing rate acceptance test report	
	T5-XXX	Leak test report	The IO acceptance of the report clear the HP
	T5-XXX	As built CAD models for the parts outside the tolerances and covered by a NCR	
	T5-XXX	As built 2D drawings	
End of manufacturing documentation	T5-XXX	End of manufacturing documentation	This includes the certificate of compliance,
		EMR (End of manufacturing Report)	all information related to welds, examinations and tests, non-conformance
<b>WP_D6 – Packing, Transport and Delivery</b>			
Packing	D6-XXX	Packing, shipping, handling procedure	The IO acceptance of the documentation clear the HP
	D6-XXX	Transportation procedure	
Delivery	D6-XXX	Delivery report	The IO acceptance of the documentation clears the HP, and is necessary to start shipment.
<b>WP_S7 - IO Site Acceptance</b>			
	S7-XXX	SAT report	
<b>WP-O8 - Option - Welding of the DD to the VVPSS Box</b>			
	O8-XXX	Acceptance of activities related to option	

## Appendix II – List of Milestones

Table 19 – List of Milestones

Milestone ref.	WBS Number	WBS Name	WP (Section 2.5)	Payment milestone	weeks from KOM
	<b>0</b>	<b>WP_PM0 – Project management and Quality</b>	<b>WP_PM0</b>		
PM0-1		Kick Off Meeting	WP_PM0		
PM0-2		Approval of PQMP and schedule baseline	WP_PM0	x	
PM0-3		Long Lead Time components identified	WP_PM0		
PM0-4		Approval of baseline SCAR, Risk register, Top level Control plan	WP_PM0		
PM0-5		Approval of the MRR Plan and of the qualification plan	WP_PM0		
PM0-6		Approval of the plan for audits and inspections at the premises of the subcontractors	WP_PM0		
PM0-7		All MRR reports approved	WP_PM0	x	KOM + 30 Weeks
	<b>1</b>	<b>WP_E1 – Engineering</b>	<b>WP_E1</b>		
E1-1		E1 - Top Level Manufacturing plan issued	WP_E1		
	<b>1.2</b>	<b>VVPSS BOX HNB1</b>	<b>WP_E1</b>		
E1.VB1-1		Schedule critical engineering activities completed for the VVPSS Box HNB1	WP_E1		
E1.VB1-2		Welding and NDE design baseline issued: Welding book and NDE summary for the VVPSS Box HNB1	WP_E1		
E1.VB1-3		Generic supplier manufacturing procedures listed and issued for the VVPSS Box HNB1	WP_E1		
E1.VB1-4		Final Manufacturing design report issued for the VVPSS Box HNB1	WP_E1		
E1.VB1-5		Welding data package approved for the VVPSS Box HNB1	WP_E1		
E1.VB1-6		MRR approved for the VVPSS Box HNB1	WP_E1	x	KOM + 30 Weeks

	1.3	VVPSS BOX HNB2	WP_E1		
E1.VB2-1		Schedule critical engineering activities completed for the VVPSS Box HNB2	WP_E1		
E1.VB2-2		Welding and NDE design baseline issued: Welding book and NDE summary for for the VVPSS Box HNB2	WP_E1		
E1.VB2-3		Generic supplier manufacturing procedures listed and issued for the VVPSS Box HNB2	WP_E1		
E1.VB2-4		Final Manufacturing design report issued for the VVPSS Box HNB2	WP_E1		
E1.VB2-5		Welding data package approved for the VVPSS Box HNB2	WP_E1		
E1.VB2-6		MRR approved for the VVPSS Box HNB2	WP_E1	x	KOM + 30 Weeks
	1.4	VVPSSB Trolley	WP_E1		
E1.VBT-1		E2.VBT - Schedule critical engineering activities completed for the VVPSSB Trolley	WP_E1		
E1.VBT-2		E3.VBT - Welding and NDE design baseline issued: Welding book and NDE summary for the VVPSSB Trolley	WP_E1		
E1.VBT-3		Generic supplier manufacturing procedures listed and issued for for the VVPSSB Trolley	WP_E1		
E1.VBT-4		Final Manufacturing design report issued for the VVPSSB Trolley	WP_E1		
E1.VBT-5		Welding data package approved for the VVPSSB Trolley	WP_E1		
E1.VBT-6		MRR approved for the VVPSSB Trolley	WP_E1	x	KOM + 30 Weeks
	1.5	Blank Flange	WP_E1		
E1.BF-1		Schedule critical engineering activities completed for the BF	WP_E1		
E1.BF-2		Welding and NDE design baseline issued: Welding book and NDE summary for BF	WP_E1		
E1.BF-3		Design of Jigs completed for BF	WP_E1		
E1.BF-4		Generic supplier manufacturing procedures listed and issued for BF	WP_E1		
E1.BF-5		Final Manufacturing design report issued for BF	WP_E1		
E1.BF-6		Welding data package approved BF	WP_E1		
E1.BF-7		MRR approved for BF	WP_E1	x	KOM + 30 Weeks

ITER\_D\_EYJES3 v1.2

	<b>1.6</b>	<b>Anchor System</b>	<b>WP_E1</b>		
E1.AS-1		Schedule critical engineering activities completed for the AS	WP_E1		
E1.AS-2		Welding, brazing and NDE design baseline issued: Welding book and NDE summary for the AS	WP_E1		
E1.AS-3		Design of Jigs completed for the AS	WP_E1		
E1.AS-4		Generic supplier manufacturing procedures listed and issued for the AS	WP_E1		
E1.AS-5		Final Manufacturing design report issued for the	WP_E1		
E1.AS-6		Welding data package approved for the AS	WP_E1		
E1.AS-7		MRR approved for the AS	WP_E1	x	KOM + 30 Weeks
	<b>1.7</b>	<b>Other Components</b>	<b>WP_E1</b>		
E1.OTH-1		Schedule critical engineering activities completed for the OTH	WP_E1		
E1.OTH-2		Welding and NDE design baseline issued: Welding book and NDE summary for for the OTH	WP_E1		
E1.OTH-3		Design of Jigs completed forfor the OTH	WP_E1		
E1.OTH-4		Generic supplier manufacturing procedures listed and issued forfor the OTH	WP_E1		
E1.OTH-5		Final Manufacturing design report issued for the OTH	WP_E1		
E1.OTH-6		Welding data package approved for the OTH	WP_E1		
E1.OTH-7		MRR approved for the OTH	WP_E1	x	KOM + 30 Weeks
	<b>2</b>	<b>WP_Q2 – Qualifications and factory preparation</b>	<b>WP_Q2</b>		
	<b>2.1</b>	<b>Other components</b>	<b>WP_Q2</b>		
Q2.OTH-1		QRR closure for the special processes (welding, brazing...) of the other components	WP_Q2		
Q2.OTH-2		Approval of the qualification for the baseline WPS for the other components	WP_Q2		
	<b>2.2</b>	<b>VVPSS BOX HNB1</b>	<b>WP_Q2</b>		
Q2.VB1-1		QRR closure for the special processes (welding, brazing...) of the VVPSS BOX HNB1	WP_Q2		
Q2.VB1-2		Approval of the qualification for the baseline WPS for of the VVPSS BOX HNB1	WP_Q2		

	<b>2.3</b>	<b>VVPSS BOX HNB2</b>	<b>WP_Q2</b>		
Q2.VB2-1		QRR closure for the special processes (welding, brazing...) of the VVPSS BOX HNB2	WP_Q2		
Q2.VB2-2		Approval of the qualification for the baseline WPS for the VVPSS BOX HNB2	WP_Q2		
	<b>2.4</b>	<b>VVPSSB Trolley</b>	<b>WP_Q2</b>		
Q2.VBT-1		QRR closure for the special processes (welding, brazing...) of the VVPSS Box Trolley	WP_Q2		
Q2.VBT-2		Approval of the qualification for the baseline WPS for the VVPSS Box Trolley	WP_Q2		
	<b>2.5</b>	<b>Blank Flange</b>	<b>WP_Q2</b>		
Q2.BF-1		QRR closure for the special processes (welding, brazing...) of the Blank Flange	WP_Q2		
Q2.BF-2		Approval of the qualification for the baseline WPS for the Blank Flange	WP_Q2		
	<b>2.6</b>	<b>Anchor System</b>	<b>WP_Q2</b>		
Q2.AS-1		QRR closure for the special processes (welding, brazing...) of the AS	WP_Q2		
Q2.AS-2		Approval of the qualification for the baseline WPS for the AS	WP_Q2		
	<b>3</b>	<b>WP_P3 - Procurement</b>	<b>WP_P3</b>		
P3-1		Off-the-shelf, purchase specification components and remaining base materials ordered	WP_P3		
	<b>3.1</b>	<b>Other components</b>	<b>WP_P3</b>		
P3.OTH-1		Start of material procurement for Other components	WP_P3		
P3.OTH-2		Procurement of material completed for Other components	WP_P3	x	
	<b>3.2</b>	<b>VVPSS BOX HNB1</b>	<b>WP_P3</b>		
P3.VB1-1		Start of procurement for the VVPSS BOX HNB1	WP_P3		
P3.VB1-2		Product qualification for SS completed (separately for each material procurer, plates, forgings,...) for VVPSS Box HNB1	WP_P3		
P3.VB1-3		Procurement of base raw material completed for the VVPSS BOX HNB1	WP_P3	x	KOM + 66 Weeks
P3.VB1-4		Filler material procurement completed for the VVPSS BOX HNB1	WP_P3		

	<b>3.3</b>	<b>VVPSS BOX HNB2</b>	<b>WP_P3</b>		
P3.VB2-1		Start of procurement for the VVPSS BOX HNB2	WP_P3		
P3.VB2-2		Product qualification for SS completed (separately for each material procurer, plates, forgings,...) for VVPSS box HNB2	WP_Q2		
P3.VB2-3		Procurement of base raw material completed for the VVPSS BOX HNB2	WP_P3	x	KOM + 66 Weeks
P3.VB2-4		Filler material procurement completed for the VVPSS BOX HNB2	WP_P3		
	<b>3.4</b>	<b>VVPSSB Trolley</b>	<b>WP_P3</b>		
P3.VBT-1		Start of material procurement for VVPSS Box Trolley	WP_P3		
P3.VBT-2		Product qualification for SS completed (separately for each material procurer, plates, forgings,...) for VVPSS Box Trolley	WP_P3		
P3.VBT-3		Procurement of base raw material completed for VVPSS Box Trolley	WP_P3	x	KOM + 66 Weeks
P3.VBT-4		Filler material procurement completed VVPSS Box Trolley	WP_P3		
	<b>3.5</b>	<b>Blank Flange</b>	<b>WP_P3</b>		
P3.BF-1		Start of material procurement for Blank Flange	WP_P3		
P3.BF-2		Product qualification for SS completed (separately for each material procurer, plates, forgings,...) for Blank Flange	WP_P3		
P3.BF-3		Procurement of base raw material completed for Blank Flange	WP_P3	x	KOM + 66 Weeks
P3.BF-4		Filler material procurement completed DD BFlows	WP_P3		
	<b>3.6</b>	<b>Anchor System</b>	<b>WP_P3</b>		
P3.AS-1		Start of material procurement for Drift Duct Assembly	WP_P3		
P3.AS-2		Product qualification for SS completed (separately for each material procurer, plates, forgings,...) for Drift Duct Assembly	WP_P3		
P3.AS-3		Procurement of base raw material completed for Drift Duct Assembly	WP_P3	x	KOM + 66 Weeks
P3.AS-4		Filler material procurement completed for Blank Flange	WP_P3		
	<b>4</b>	<b>WP_M4 – Manufacturing</b>	<b>WP_M4</b>		
	<b>4.1</b>	<b>Other components</b>	<b>WP_M4</b>		
M4.OTH-1		Start of manufacturing for Other components	WP_M4		

ITER\_D\_EYJES3 v1.2

M4.OTH-2		Manufacturing, control, and cleaning of the closure plate 067836	WP_M4		
M4.OTH-3		Manufacturing, control, and cleaning of the closure plate 067759	WP_M4		
M4.OTH-4		Manufacturing and testing completed for the other components	WP_M4		
M4.OTH-5		Intermediate cleaning completed for the other components	WP_M4		
	<b>4.2</b>	<b>VVPSS BOX HNB1</b>	WP_M4		
M4.VB1-1		Start of manufacturing for VB1	WP_M4		
M4.VB1-2		TBD by the manufacturer	WP_M4		
M4.VB1-3		TBD by the manufacturer	WP_M4		
M4.VB1-4		TBD by the manufacturer	WP_M4		
M4.VB1-5		Manufacturing and testing completed for VB1	WP_M4	x	KOM + 90 Weeks
M4.VB1-6		Intermediate cleaning completed for VB1	WP_M4		
	<b>4.3</b>	<b>VVPSS BOX HNB2</b>	WP_M4		
M4.VB2-1		Start of manufacturing for VB2	WP_M4		
M4.VB2-2.1		TBD by the manufacturer	WP_M4		
M4.VB2-2.2		TBD by the manufacturer	WP_M4		
M4.VB2-2.xxx		TBD by the manufacturer	WP_M4		
M4.VB2-5		Manufacturing and testing completed for VB2	WP_M4	x	KOM + 110 Weeks
M4.VB2-6		Intermediate cleaning completed for VB2	WP_M4		
	<b>4.4</b>	<b>VVPSSB Trolley</b>	WP_M4		
M4.VBT-1		Start of manufacturing for VVPSS Box Trolley	WP_M4		
M4.VBT-2.1		TBD by the manufacturer	WP_M4		
M4.VBT-2.2		TBD by the manufacturer	WP_M4		
M4.VBT-2.xxxx		TBD by the manufacturer	WP_M4		
M4.VBT-5		Manufacturing and testing completed for for VVPSS Box Trolley	WP_M4	x	KOM + 130 Weeks
M4.VBT-6		Intermediate cleaning completed for for VVPSS Box Trolley	WP_M4		
	<b>4.5</b>	<b>Blank Flange</b>	WP_M4		
M4.BF-1		Start of manufacturing for Blank Flange	WP_M4		

ITER\_D\_EYJES3 v1.2

M4.BF-2		TBD by the manufacturer	WP_M4		
M4.BF-3		TBD by the manufacturer	WP_M4		
M4.BF-4		TBD by the manufacturer	WP_M4		
M4.BF-5		Manufacturing and testing completed for BF	WP_M4	x	KOM + 124 Weeks
M4.BF-6		Intermediate cleaning completed for BF	WP_M4		
	<b>4.6</b>	<b>Anchor System</b>	WP_M4		
M4.AS-1		Start of manufacturing for AS	WP_M4		
M4.AS-2		TBD by the manufacturer	WP_M4		
M4.AS-3		TBD by the manufacturer	WP_M4		
M4.AS-4		TBD by the manufacturer	WP_M4		
M4.AS-5		Manufacturing and testing completed for AS	WP_M4	x	KOM + 124 Weeks
M4.AS-6		Intermediate cleaning completed for AS	WP_M4		
	<b>5</b>	<b>WP_T5 – Factory Acceptance Testing</b>	<b>WP_T5</b>		
T5-1		Facility readiness for Factory acceptance tests	WP_T5		
T5-2		Start of the outgassing rate acceptance test	WP_T5		
T5.HNB1-1		Start of FAT for the HNB1 VVPSS Box HNB1	WP_T5		
T5.HNB1-2		Electrical test of thermocouples and heating elements for the VVPSS box HNB1 Completed	WP_T5		
T5.HNB1-3		Functional test of the assembly for the HNB1 VVPSS Box Trolley Completed	WP_T5		
T5.HNB1-4		Functional test of the assembly for the HNB1 Anchor System	WP_T5		
T5.HNB1-5		Flow and pressure drop test for the HNB1 DD Completed	WP_T5		
T5.HNB1-6		Vacuum leak test at room temperature for the HNB1 DD Completed	WP_T5	x	
T5.HNB1-7		Test of the baking capability for the VVPSS box HNB1 Completed	WP_T5		
T5.HNB1-8		Hot vacuum leak test for the VVPSS box HNB1 Completed	WP_T5		
T5.HNB1-9		FAT completed for the HNB1	WP_T5	x	KOM + 150 Weeks
T5.HNB2-1		Start of FAT for the HNB2 VVPSS Box HNB2	WP_T5		
T5.HNB2-2		Electrical test of thermocouples and heating elements for the VVPSS box HNB2 Completed	WP_T5		

ITER\_D\_EYJES3 v1.2

T5.HNB2-3		Functional test of the assembly for the HNB2 VVPSS Box Trolley Completed	WP_T5		
T5.HNB2-4		Functional test of the assembly for the HNB2 Anchor System	WP_T5		
T5.HNB2-5		Flow and pressure drop test for the HNB2 DD Completed	WP_T5		
T5.HNB2-6		Vacuum leak test at room temperature for the HNB2 DD Completed	WP_T5	x	
T5.HNB2-7		Test of the baking capability for the VVPSS box HNB2 Completed	WP_T5		
T5.HNB2-8		Hot vacuum leak test for the VVPSS box HNB2 Completed	WP_T5		
T5.HNB2-9		FAT completed for the HNB2	WP_T5	x	KOM + 150 Weeks
	<b>6</b>	<b>WP_D6 – Packing, Transport and Delivery</b>	<b>WP_D6</b>		
D6-1		Design of final transportation equipment started	WP_D6		
D6-2		Fabrication of transportation equipment started	WP_D6		
D6-3		Transportation equipment ready at supplier factory	WP_D6		
D6.VB1-1		Delivery Readiness Review Approved	WP_D6		
D6.VB2		Delivery Readiness Review Approved	WP_D6		
D6.VBT		Delivery Readiness Review Approved	WP_D6		
D6.BF		Delivery Readiness Review Approved	WP_D6		
D6.AS		Delivery Readiness Review Approved	WP_D6		
D6-4		Packing and delivery of spares and other components completed	WP_D6		
D6-5		Delivery Acceptance approved by IO for spares and other components	WP_D6		
D6.HNB1-1		Packing and delivery of HNB1 VVPSS box ITEMS completed	WP_D6		KOM + 165 Weeks
D6.HNB1-2		Delivery Acceptance approved by IO for HNB1 VVPSS box ITEMS	WP_D6	x	
D6.HNB2-1		Packing and delivery of HNB2 VVPSS BOX ITEMS completed	WP_D6		KOM + 165 Weeks
D6.HNB2-2		Delivery Acceptance approved by IO for HNB2 VVPSS BOX ITEMS	WP_D6	x	
	<b>7</b>	<b>WP_S7 - IO Site Acceptance</b>	<b>WP_S7</b>		
S7-1		Final acceptance by IO of spares and other components	WP_S7		
S7.HNB1		Final acceptance by IO of HNB1 VVPSS BOX ITEMS	WP_S7	x	
S7.HNB2		Final acceptance by IO of HNB2 VVPSS BOX ITEMS	WP_S7	x	

ITER\_D\_EYJES3 v1.2

S7-2		Final ADP for contract closure approved	WP_S7	x	KOM + 180 Weeks
	<b>8</b>	<b>Option - Welding of the DD to the VVPSS Box</b>			
O8-1		Release of option	OPTION		TBD - KOM
O8-2		Engineering activities related to option completed	OPTION		TBD - KOM
O8-3		On site activities related to option completed	OPTION		TBD - KOM
O8-4		Acceptance of activities related to option	OPTION	x	TBD - KOM

## Appendix III – Clarifications



china eu india japan korea russia usa

Route de Vinon-sur-Verdon - CS 90 046 - 13067 St Paul Lez Durance Cedex - France

19 March 2026

To: Domestic Agencies (DAs)

**IO Tender Reference: IO/26/OT/10033393/JPK**

**Title: Procurement of the Heating Neutral Beam 1 (HNB1) and Heating Neutral Beam 2 (HNB2) Vacuum Vessel Pressure Suppression System (VVPSS) Components (B).**

**Subject: Prior Indicative Notice (PIN)**

Dear colleagues,

The ITER Organization intends to launch an Open Tender process in the coming weeks as indicated above and in accordance with the details in the attached Prior Indicative Notice (PIN). In this regard, and to provide some introductory information about the forthcoming tender, we kindly request the attached PIN to be published on your DA website with immediate effect for a period of **12** working days.

china

eu

india

japan

korea

russia

usa

The advance notification is to alert companies, institutions, or other eligible entities to the forthcoming tender, and provide information to promote healthy competition, allowing interested parties time to decide whether to participate in the tender or not.

Please could you kindly acknowledge receipt of this e-mail and confirm once the PIN is published on your website.

Yours sincerely

JunHyung PARK  
Procurement Officer  
Procurement Division

EXPRESSION OF INTEREST & PIN ACKNOWLEDGEMENT

To be returned by e-mail to: Junhyung.park@iter.org copy to Andrew.Brown@iter.org

Company Name: \_\_\_\_\_

TENDER No. **IO/26/OT/10033393/JPK**

DESIGNATION of SERVICES: **Procurement of the Heating Neutral Beam 1 (HNB1) and Heating Neutral Beam 2 (HNB2) Vacuum Vessel Pressure Suppression System (VVPSS) Components (B)**

OFFICER IN CHARGE: **JunHyung PARK – Procurement Division ITER Organization**

- WE ACKNOWLEDGE HAVING READ THE PIN NOTICE FOR THE ABOVE MENTIONED TENDER
- WE INTEND TO SUBMIT A TENDER

Are you registered in Iproc (only entities registered in iPROC will be invited to tender)?:

- YES

Please indicate your registration number: .....

- NO, but we shall register before the indicated tender launch date

**Please list the users of ARIBA/IPROC that you wish to add as response team for this tender:**

Name	E-mail
...	...

.....

Signature:

**Contact person:** .....

COMPANY STAMP

Position: .....

Tel: .....

E-mail .....

Date: .....